

Cartridge Valve

- Pressure Control
- Flow Control
- Directional
- Load Holding
- Logic Element
- Specialty
- Proportional
- Cavity Plug



Contents

Cartridge Valve

Operating Recommendation	05
Index	06
Pressure Control	
Pilot Operated Relief Valve	RP14
Direct-acting Relief Valve	RD 16
Pilot Operated Relief Valve with Vent	RV 18
Pilot Operated Sequence Valve	RS 20
Pilot Operated Reducing Valve	PB 22
Pilot Operated Reducing / Relieving Valve	PP 24
Direct-acting Pressure Reducing / Relieving Valve	PR 26
Flow Control	
Fully Adjustable Needle Valve	NFC 28
Fully Adjustable and High Capacity Needle Valve	NFD 30
Fully Adjustable Needle Valve (with Free Flow Check Valve)	NCB 32
Pressure Compensated Fully Adjustable Flow Control Valve (with Free Flow Check Valve)	FD 34
Normally Closed, Modulating Element with Pilot Source from Port 1	LRA 36
Normally Closed, Modulating Element	LRC 38
Directional	
Pilot to Open Check Valve	CKB 40
Vented, Pilot to Open Check Valve	CKF 42
Pilot to Close Check Valve.....	CO 44
Shuttle Valve.....	CS 46
Check Valve (Free Flow Port1 to Port2)	CXA 48
Check Valve (Free Flow Por2 to Port1)	CXD 50
Load Holding	
Counterbalance 3:1 Pilot Ratio External Pilot Non-Vented Valve	CBA 52
Counterbalance 4.5:1 Pilot Ratio External Pilot Non-Vented Valve.....	CBG 54
Counterbalance 10:1 Pilot Ratio External Pilot Non-Vented Valve	CBH 56
3:1 Pilot Ratio, Semi-restrictive Counterbalance Valve	CBC 58
4.5:1 Pilot Ratio, Semi-restrictive Counterbalance Valve	CBD 60

(continue)

Contents

Cartridge Valve

3:1 Pilot Ratio, Restrictive Counterbalance Valve	CBE	62
4.5:1 Pilot Ratio, Restrictive Counterbalance Valve	CBF	64
Logic Element		
Logic Elements	LO	66
Specialty		
30%, Accumulator Sense, Pump Unload Valve with Check - Pilot Capacity	QC	68
Cavity Plug		
2 Holes External Port Blocked Cavity Plug.....	OA2	70
2 Holes All Ports Blocked Cavity Plug.....	CA2	71
Port 1 to 2 Open, Port 3 Blocked Cavity Plug	OA3	72
3 Holes All Ports Blocked Cavity Plug.....	CA3	73
SAE Cavity Cartridge Valve > Pressure Control		
Noiseless Direct Acting Diagonal Area Relief Valve	MH	74
SAE Cavity Cartridge Valve > Flow Control		
Check with Manual Adjustment	CN	76
Fully Adjustable Needle	NV	78
Fully Adjustable Needle with Free Flow Check	NC	80
Flow Divider (Flow Ratio: 1:1)	CP	82
SAE Cavity Cartridge Valve > Directional		
Check Free Flow 1-2	CV	84
Shuttle Valve	LS	86
Solenoid On/Off Valves 2-Way Valve	HS, JS, LS, PS-2	88
Solenoid On/Off Valves 3-Way Valve	HS-3	90
SAE Cavity Cartridge Valve > Proportional		
Normally Closed, 2 Way Proportional Flow Control Valve	PV-1033	92
3 Way Normally Closed, Pressure Compensated, Proportional Flow Control Valve	EVP-M33	94
Cavities Tooling		96
Cavities Tooling (SAE Cavity)		100

Operating Recommendation

· **Fluid Viscosity Recommendations**

15 to 380 cSt

· **Fluid Cleanliness Recommendations**

Specified in accordance with ISO 4406:1999; 4µm / 6µm / 14µm

· **Fluid Temperature Recommendations**

Buna N (Nitrile) : -35°C to 90°C

Viton : -20°C to 120°C

CONTROL MANNER

► **L : Standard Screw Adjustment**

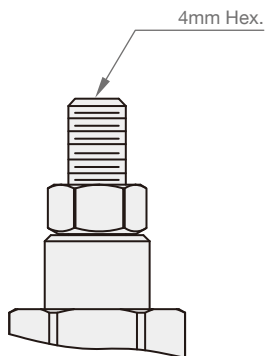

► **K : Hand Knob with Lock Knob**

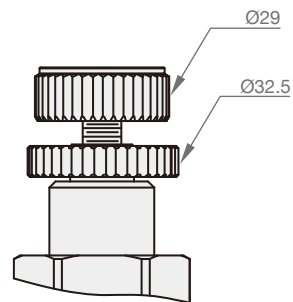

► **C : Tamper Resistant Cover**

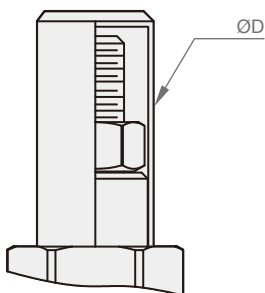

ØD	Size	Cavity
Ø19	02	T10, T11, T13
Ø25	03	T2, T3, T5
Ø30	06	T16, T17
Ø40	08	T18, T19

Index

Pressure Control

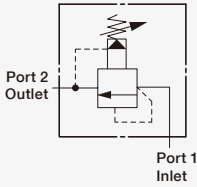
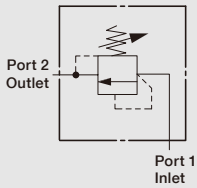
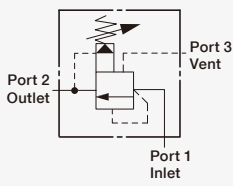
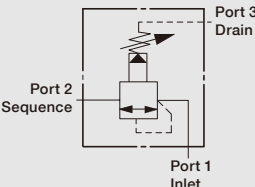
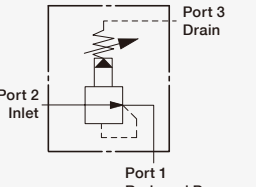
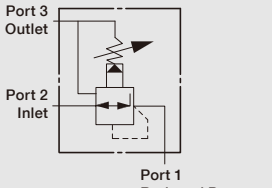
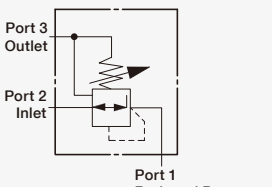
Page No.	Function	Symbols	Model No.	Cavity	Capacity (l/min)	Control Manner		
						L	K	X
14	Pilot Operated Relief Valve		RP2C	T10A	95	✓	✓	
			RP3C	T3A	200	✓	✓	
			RP6C	T16A	380	✓	✓	
			RP8C	T18A	760	✓	✓	
16	Direct-acting Relief Valve		RD2A	T10A	95	✓		
			RD3A	T3A	200	✓		
			RD6A	T16A	380	✓		
			RD8A	T18A	760	✓		
18	Pilot Operated Relief Valve with Vent		RV2A	T11A	60	✓	✓	
			RV3A	T2A	120	✓	✓	
			RV6A	T17A	240	✓	✓	
			RV8A	T19A	480	✓	✓	
20	Pilot Operated Sequence Valve		RS2C	T11A	60	✓	✓	
			RS3C	T2A	120	✓	✓	
			RS6C	T17A	240	✓	✓	
			RS8C	T19A	480	✓	✓	
22	Pilot Operated Reducing Valve		PB2B	T11A	40	✓	✓	
			PB3B	T2A	80	✓	✓	
			PB6B	T17A	160	✓	✓	
			PB8B	T19A	320	✓	✓	
24	Pilot Operated Reducing / Relieving Valve		PP2B	T11A	40	✓	✓	
			PP3B	T2A	80	✓	✓	
			PP6B	T17A	160	✓	✓	
			PP8B	T19A	320	✓	✓	
26	Direct-acting Pressure Reducing / Relieving Valve		PR2B	T11A	40	✓	✓	
			PR3B	T2A	80	✓	✓	
			PR6B	T17A	160	✓	✓	
			PR8B	T19A	320	✓	✓	

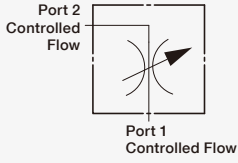
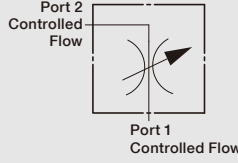
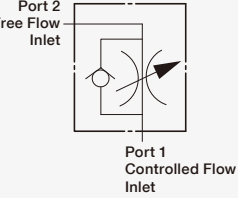
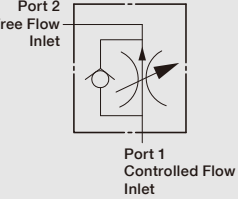
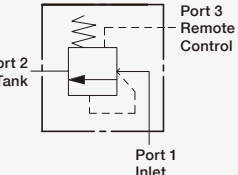
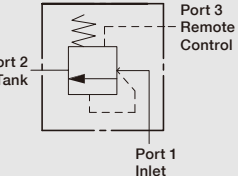
Page No.	Function	Symbols	Model No.	Cavity	Capacity (l/min)	Control Manner		
						L	K	X
28	Fully Adjustable Needle Valve		NF2C	T13A	25	✓	✓	
			NF3C	T5A	50	✓	✓	
			NF6C	T16A	100	✓	✓	
			NF8C	T18A	200	✓	✓	
30	Fully Adjustable and High Capacity Needle Valve		NF2D	T13A	80	✓	✓	
			NF3D	T5A	160	✓	✓	
			NF6D	T16A	320	✓	✓	
			NF8D	T18A	500	✓	✓	
32	Fully Adjustable Needle Valve (with Free Flow Check Valve)		NC2B	T13A	25	✓	✓	
			NC3B	T5A	50	✓	✓	
			NC6B	T16A	100	✓	✓	
			NC8B	T18A	200	✓	✓	
34	Pressure Compensated Fully Adjustable Flow Control Valve (with Free Flow Check Valve)		FD2A	T13A	23	✓	✓	
			FD3B	T5A	45	✓	✓	
			FD6A	T16A	95	✓	✓	
			FD8A	T18A	200	✓	✓	
36	Normally Closed, Modulating Element with Pilot Source from Port 1		LR2A	T11A	60	✓		✓
			LR3A	T2A	120	✓		✓
			LR6A	T17A	240	✓		✓
			LR8A	T19A	480	✓		✓
38	Normally Closed, Modulating Element		LR2C	T11A	60	✓		✓
			LR3C	T2A	120	✓		✓
			LR6C	T17A	240	✓		✓
			LR8C	T19A	480	✓		✓

Page No.	Function	Symbols	Model No.	Cavity	Capacity (l/min)	Control Manner		
						L	K	X
40	Pilot to Open Check Valve		CK2B	T11A	60			✓
			CK3B	T2A	120			✓
			CK6B	T17A	240			✓
			CK8B	T19A	480			✓
42	Vented, Pilot to Open Check Valve		CK2F	T11A	60			
			CK3F	T2A	120			
			CK6F	T17A	240			
			CK8F	T19A	480			
44	Pilot to Close Check Valve		CO1A	T163A	40			✓
			CO2A	T11A	80			✓
			CO3A	T2A	160			✓
			CO6A	T17A	320			✓
			CO8A	T19A	640			✓
46	Shuttle Valve		CS1Z	T163A	5			✓
			CS2D	T11A	10			✓
			CS1X	T163A	5			✓
			CS2B	T11A	10			✓
48	Check Valve (Free Flow Port1 to Port2)		CX2A	T13A	80			✓
			CX3A	T5A	160			✓
			CX7A	T16A	320			✓
			CX8A	T18A	640			✓
50	Check Valve (Free Flow Port2 to Port1)		CX2D	T13A	60			✓
			CX3D	T5A	120			✓
			CX7D	T16A	240			✓
			CX8D	T18A	480			✓

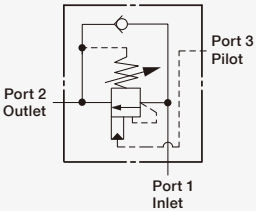
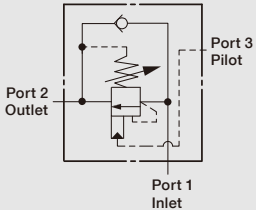
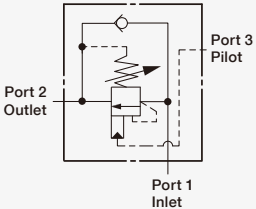
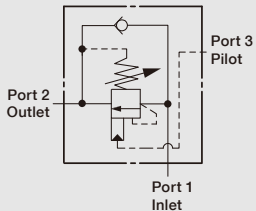
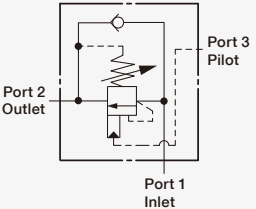
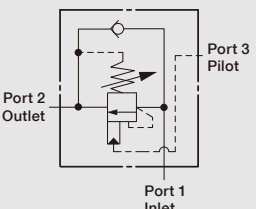
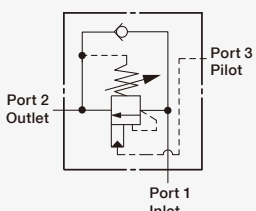
Page No.	Function	Symbols	Model No.	Cavity	Capacity (l/min)	Control Manner		
						L	K	X
52	Counterbalance 3:1 Pilot Ratio External Pilot Non-Vented Valve		CB2A	T11A	60	✓		
			CB3A	T2A	120	✓		
			CB6A	T17A	240	✓		
			CB8A	T19A	480	✓		
54	Counterbalance 4.5:1 Pilot Ratio External Pilot Non-Vented Valve		CB2G	T11A	60	✓		
			CB3G	T2A	120	✓		
			CB6G	T17A	240	✓		
			CB8G	T19A	480	✓		
56	Counterbalance 10:1 Pilot Ratio External Pilot Non-Vented Valve		CB2H	T11A	60	✓		
			CB3H	T2A	120	✓		
			CB6H	T17A	240	✓		
			CB8H	T19A	480	✓		
58	3:1 Pilot Ratio, Semi-restrictive Counterbalance Valve		CB2C	T11A	40	✓		
			CB3C	T2A	80	✓		
			CB6C	T17A	160	✓		
60	4.5:1 Pilot Ratio, Semi-restrictive Counterbalance Valve		CB2D	T11A	40	✓		
			CB3D	T2A	80	✓		
			CB6D	T17A	160	✓		
62	3:1 Pilot Ratio, Restrictive Counterbalance Valve		CB2E	T11A	15	✓		
			CB3E	T2A	30	✓		
			CB6E	T17A	60	✓		
			CB8E	T19A	80	✓		
64	4.5:1 Pilot Ratio, Restrictive Counterbalance Valve		CB2F	T11A	15	✓		
			CB3F	T2A	30	✓		
			CB6F	T17A	60	✓		
			CB8F	T19A	80	✓		

Logic Element

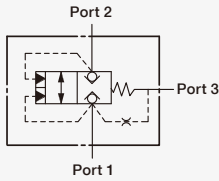
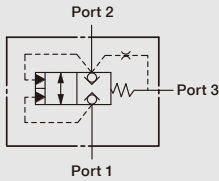
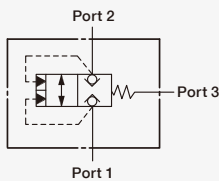
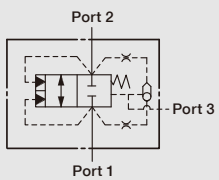
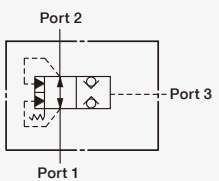
Page No.	Function	Symbols	Model No.	Cavity	Capacity (l/min)	Control Manner		
						L	K	X
66	Logic Elements (Spring biased closed, pilot source from port 1)		LO2A	T11A	80	✓		✓
			LO3A	T2A	160	✓		✓
			LO6A	T17A	320	✓		✓
			LO8A	T19A	640	✓		✓
66	Logic Elements (Spring biased closed, pilot source from port 2)		LO2B	T11A	80	✓		✓
			LO3B	T2A	160	✓		✓
			LO6B	T17A	320	✓		✓
			LO8B	T19A	640	✓		✓
66	Logic Elements (Spring biased closed, pilot source from port 3)		LO2C	T11A	80	✓		✓
			LO3C	T2A	160	✓		✓
			LO6C	T17A	320	✓		✓
			LO8C	T19A	640	✓		✓
66	Logic Elements (Spring biased closed, higher of port 1 or 2 pilot source)		LO2D	T11A	80	✓		✓
			LO3D	T2A	160	✓		✓
			LO6D	T17A	320	✓		✓
			LO8D	T19A	640	✓		✓
66	Logic Elements (Spring biased open, pilot source from port 3)		LO2O	T11A	80	✓		✓
			LO3O	T2A	160	✓		✓
			LO6O	T17A	320	✓		✓
			LO8O	T19A	640	✓		✓

Specialty

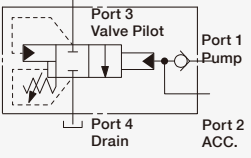
Page No.	Function	Symbols	Model No.	Cavity	Capacity (l/min)	Control Manner		
						L	K	X
68	30%, Accumulator Sense, Pump Unload Valve with Check - Pilot Capacity		QC2C	T21A	60	✓	✓	

Cavity Plug

Page No.	Function	Symbols	Model No.	Cavity	Thread
70	2 Holes External Port Blocked Cavity Plug		X10A2	T162A	M16 P15
			X20A2	T10A	M20 P1.5
			X20A2	T13A	M20 P1.5
			X30A2	T3A	1"-14UNS-2B
			X30A2	T5A	1"-14UNS-2B
			X60A2	T16A	M36 P2
			X80A2	T18A	M48 P2
71	2 Holes All Ports Blocked Cavity Plug		X1CA2	T162A	M16 P15
			X2CA2	T10A	M20 P1.5
			X2CA2	T13A	M20 P1.5
			X3CA2	T3A	1"-14UNS-2B
			X3CA2	T5A	1"-14UNS-2B
			X6CA2	T16A	M36 P2
			X8CA2	T18A	M48 P2
72	Port 1 to 2 Open, Port 3 Blocked Cavity Plug		X10A3	T163A	M16 P1.5
			X20A3	T11A	M20 P1.5
			X30A3	T2A	1"-14UNS-2B
			X60A3	T17A	M36 P2
			X80A3	T19A	M48 P2
73	3 Holes All Ports Blocked Cavity Plug		X1CA3	T163A	M16 P1.5
			X2CA3	T13A	M20 P1.5
			X3CA3	T2A	1"-14UNS-2B
			X6CA3	T17A	M36 P2
			X8CA3	T19A	M48 P2

SAE Cavity Cartridge Valve > Pressure Control

Page No.	Function	Symbols	Model No.	Cavity	Capacity (l/min)	Control Manner			
						L	K	X	V
74	Noiseless Direct Acting Diagonal Area Relief Valve		MH-082	T082	25	✓	✓		✓
			MH-092	T092	45	✓	✓		✓
			MH-102	T102	55	✓	✓		✓

SAE Cavity Cartridge Valve > Flow Control

Page No.	Function	Symbols	Model No.	Cavity	Capacity (l/min)	Control Manner		
						L	K	X
76	Check with Manual Flow Adjustment		CN-082	T082	30	✓	✓	
			CN-102	T102	50	✓	✓	
			CN-122	T122	80	✓	✓	
			CN-162	T162	150	✓	✓	
78	Fully Adjustable Needle		NV-082	T082	30	✓	✓	
			NV-102	T102	50	✓	✓	
			NV-122	T122	80	✓	✓	
			NV-162	T162	150	✓	✓	
80	Fully Adjustable Needle with Free Flow Check		NC-082	T082	30	✓	✓	
			NC-102	T102	50	✓	✓	
			NC-122	T122	80	✓	✓	
			NC-162	T162	150	✓	✓	
82	Flow Divider (Flow Ratio: 1:1)		CP-104	T104	45			✓
			CP-124	T124	75			✓
			CP-164	T164	150			✓

SAE Cavity Cartridge Valve > Directional

Page No.	Function	Symbols	Model No.	Cavity	Capacity (l/min)	Control Manner		
						L	K	X
84	Check Free Flow 1-2		CV-082	T082	30			✓
			CV-102	T102	50			✓
			CV-122	T122	80			✓
			CV-162	T162	150			✓
86	Shuttle Valve		LS-083	T083	15			✓
			LS-103	T103	30			✓

SAE Cavity Cartridge Valve > Directional

Page No.	Function	Symbols	Model No.	Cavity	Capacity (l/min)	
					12 VDC	24 VDC
88	Solenoid On/Off Valves 2-Way Valve		HS-2A-16	T082	28	
			HS-2B-16	T082	28	
			HS-2C-16	T082	28	
			HS-2D-16	T082	30	
			HS-2J-16	T082	12	
			JS-2A-16	T102	50	
			JS-2B-16	T102	50	
			JS-2C-16	T102	50	
			JS-2D-16	T102	55	
			JS-2I-16	T102	20	
			HS-2J-16	T082	12	
			LS-2A-16	T122	100	
			LS-2B-16	T122	100	
			LS-2C-16	T122	100	
			LS-2D-16	T122	105	
			LS-2I-16	T122	40	
			PS-2A-19	T162	150	
			PS-2B-19	T162	150	
PS-2C-19	T162	150				
PS-2D-19	T162	150				
PS-2I-19	T162	60				
90	Solenoid On/Off Valves 3-Way Valve		HS-3A-16	T082	15	
			HS-3D-16	T082	11	
			HS-3X-16	T082	13	

SAE Cavity Cartridge Valve > Proportional

Page No.	Function	Symbols	Model No.	Cavity	Capacity (l/min)	Max. Current (mA)	
						12 VDC	24 VDC
92	Normally Closed, 2 Way Proportional Flow Control Valve		PV-1033	T103	30	1800	900
94	3 Way Normally Closed, Pressure Compensated, Proportional Flow Control Valve		EVP-M33	C332-3	50	1900	950

RP



SYMBOLS

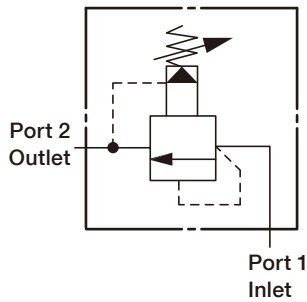

ORDER CODES

RP **2C** - **T10A** - **L** **A** **N**

1 2 3 4 5 6

1	Model Name	RP	
2	Valve Size	2C, 3C, 6C, 8C	
3	Cavity	T10A, T3A, T16A, T18A	
4	Control Manner	L	standard screw adjustment
		K	hand knob with lock knob
5	Adjustable Range	A	7 ~ 210 bar
		B	3.5 ~ 105 bar
		C	10 ~ 400 bar
		E	2 ~ 25 bar
6	Material of Seal	N	buna-N
		V	viton

MODEL SPEC.

Model	Cavity	Capacity (l/min)	Max. Pressure (bar)	Installation Torque (Nm)	Operational Temperature	Weight (kg)
RP2C	T10A	95	350	40/50	-35 ~ 100°C (-31 ~ 212°F)	0.15
RP3C	T3A	200	350	60/70		0.25
RP6C	T16A	380	350	200/215		0.55
RP8C	T18A	760	350	465/500		1.17

PERFORMANCE CURVES

► Typical Pressure Rise

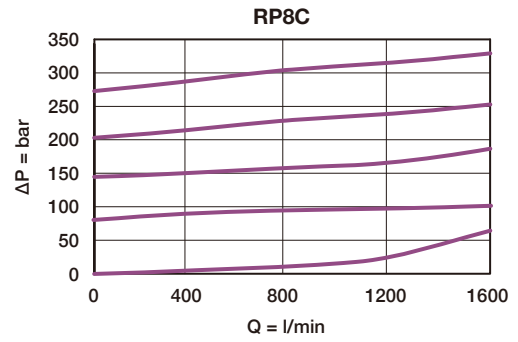
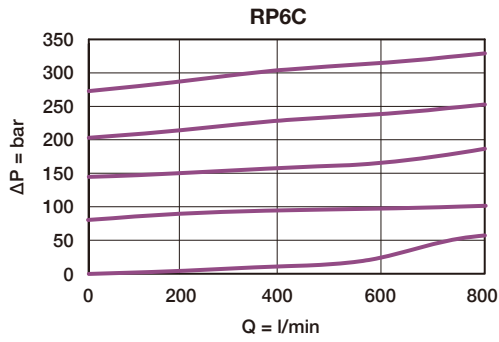
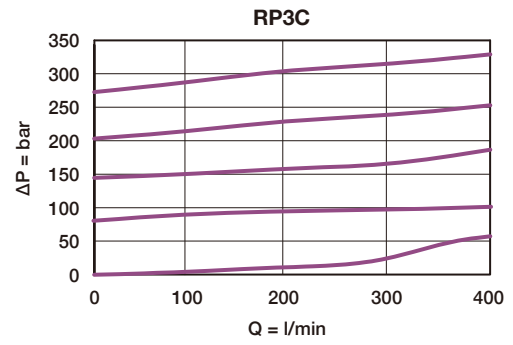
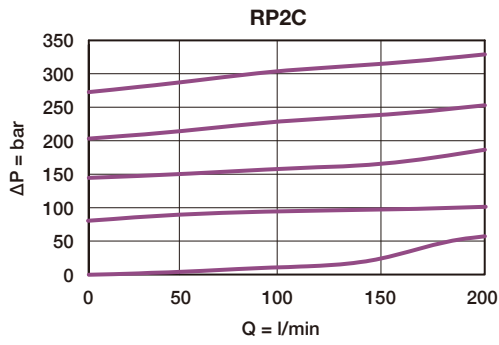

DIMENSION

(UNIT : mm)

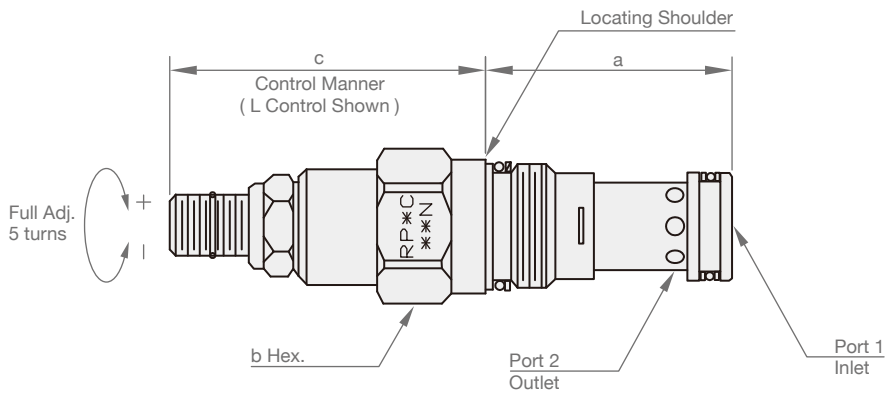

Model	a	b	c	
			L	K
RP2C	39.7	22.2	51	58
RP3C	47.8	28.6	54	61
RP6C	61.9	31.8	62	69
RP8C	79.4	41.3	71	78

RD



SYMBOLS

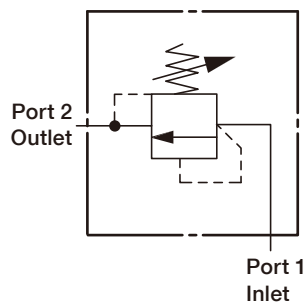

ORDER CODES

RD **2A** - **T10A** - **L** **A** **N**

1 2 3 4 5 6

1	Model Name	RD	
2	Valve Size	2A, 3A, 6A, 8A	
3	Cavity	T10A, T3A, T16A, T18A	
4	Control Manner	L	standard screw adjustment
5	Adjustable Range	A	35 ~ 210 bar
		B	20 ~ 105 bar
		E	7 ~ 25 bar
		W	70 ~ 315 bar
6	Material of Seal	N	buna-N
		V	viton

MODEL SPEC.

Model	Cavity	Capacity (l/min)	Max. Pressure (bar)	Installation Torque (Nm)	Operational Temperature	Weight (kg)
RD2A	T10A	95	350	40/50	-35 ~ 100°C (-31 ~ 212°F)	0.155
RD3A	T3A	200	350	60/70		0.295
RD6A	T16A	380	350	200/215		0.670
RD8A	T18A	760	350	465/500		1.450

PERFORMANCE CURVES

► Typical Pressure Rise

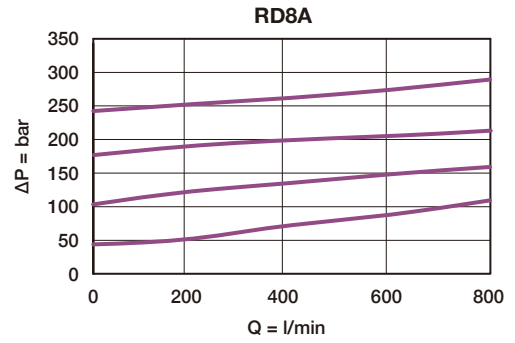
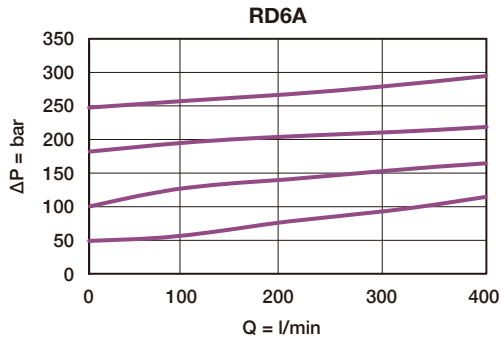
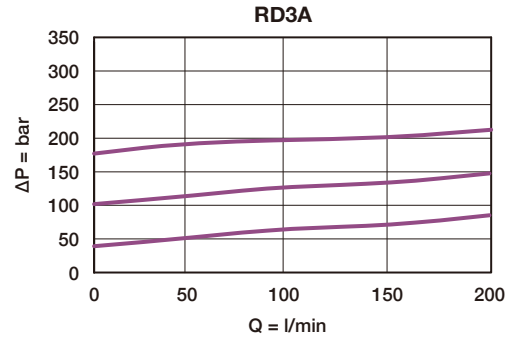
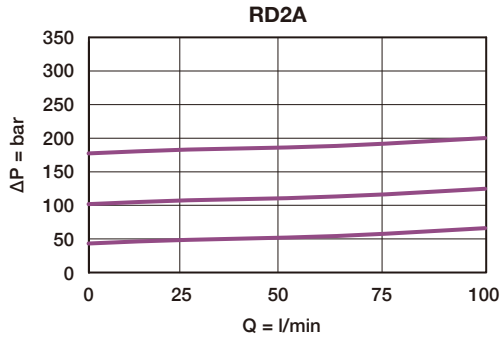

DIMENSION

(UNIT : mm)

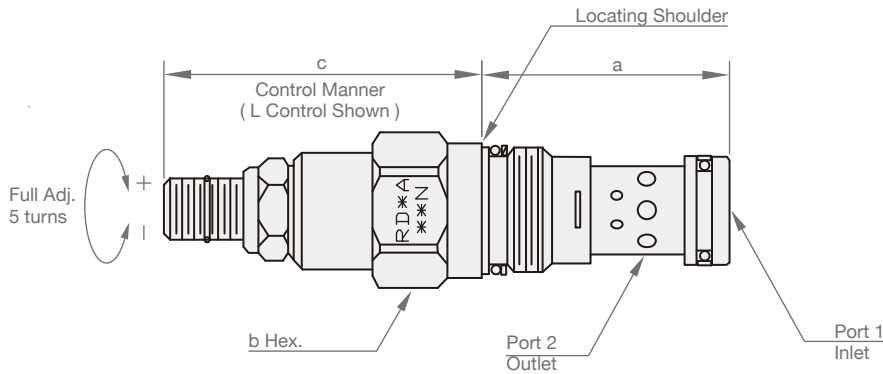

Model	a	b	c
			L
RD2A	39.7	22.2	61
RD3A	47.8	28.6	64
RD6A	61.9	31.8	83
RD8A	79.4	41.3	100

RV



SYMBOLS

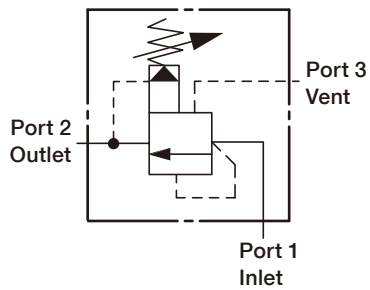

ORDER CODES

RV 2A - T11A - L A N

1 2 3 4 5 6

1	▶ Model Name	RV
2	▶ Valve Size	2A, 3A, 6A, 8A
3	▶ Cavity	T11A, T2A, T17A, T19A
4	▶ Control Manner	L standard screw adjustment
		K hand knob with lock knob
5	▶ Adjustable Range	A 7 ~ 210 bar
		B 3.5 ~105 bar
		C 10 ~ 400 bar
		E 2 ~ 25 bar
6	▶ Material of Seal	N buna-N
		V viton

MODEL SPEC.

Model	Cavity	Capacity (l/min)	Max. Pressure (bar)	Installation Torque (Nm)	Operational Temperature	Weight (kg)
RV2A	T11A	60	350	40/50	-35 ~ 100°C (-31 ~ 212°F)	0.17
RV3A	T2A	120	350	60/70		0.30
RV6A	T17A	240	350	200/215		0.64
RV8A	T19A	480	350	465/500		1.43

PERFORMANCE CURVES

► Vented Pressure

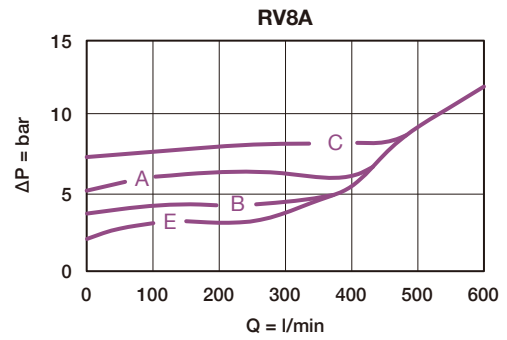
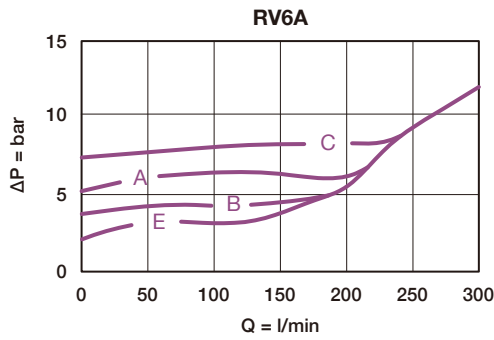
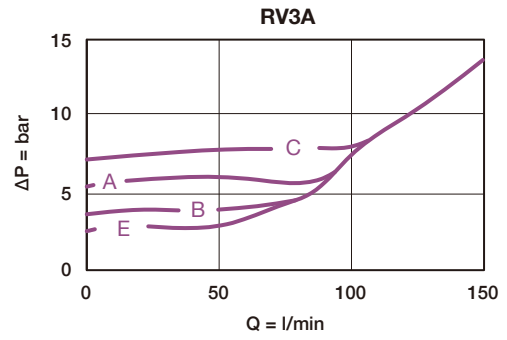
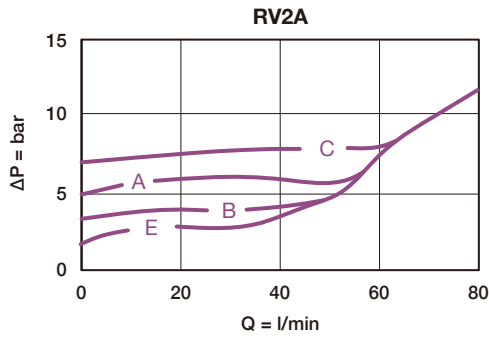

DIMENSION

(UNIT : mm)

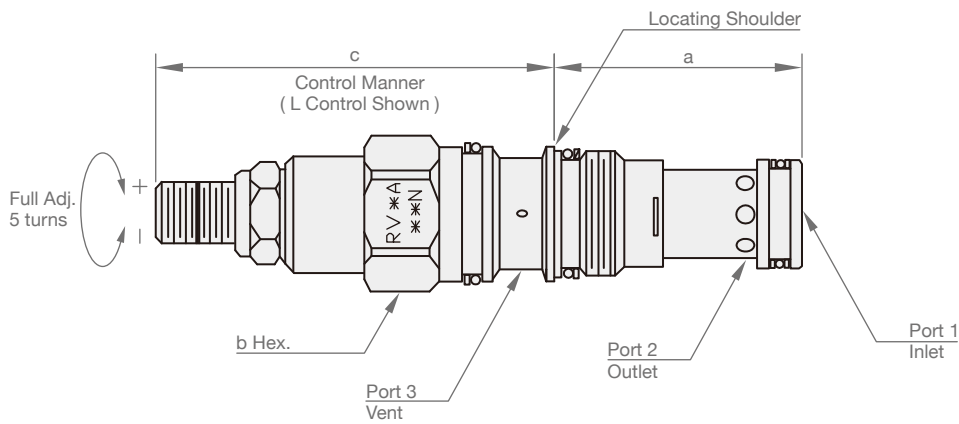

Model	a	b	c	
			L	K
RV2A	34.9	22.2	64	70
RV3A	34.9	28.6	72	78
RV6A	46.0	31.8	84	90
RV8A	63.5	41.3	100	107

RS



SYMBOLS

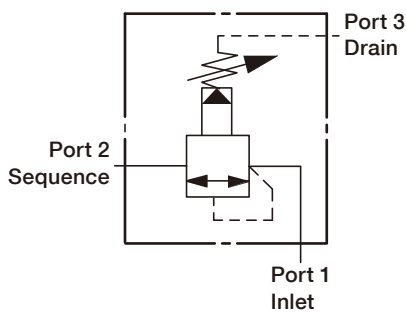

ORDER CODES

RS **2C** - **T11A** - **L** **A** **N**

1 2 3 4 5 6

1	▶ Model Name	RS	
2	▶ Valve Size	2C, 3C, 6C, 8C	
3	▶ Cavity	T11A, T2A, T17A, T19A	
4	▶ Control Manner	L	standard screw adjustment
		K	hand knob with lock knob
5	▶ Adjustable Range	A	7 ~ 210 bar
		B	3.5 ~105 bar
		N	4 ~ 55 bar
		W	10 ~ 315 bar
6	▶ Material of Seal	N	buna-N
		V	viton

MODEL SPEC.

Model	Cavity	Capacity (l/min)	Max. Pressure (bar)	Installation Torque (Nm)	Operational Temperature	Weight (kg)
RS2C	T11A	60	350	40/50	-35 ~ 100°C (-31 ~ 212°F)	0.17
RS3C	T2A	120	350	60/70		0.30
RS6C	T17A	240	350	200/215		0.64
RS8C	T19A	480	350	465/500		1.43

PERFORMANCE CURVES

► Pressure Drop Fully Sequence

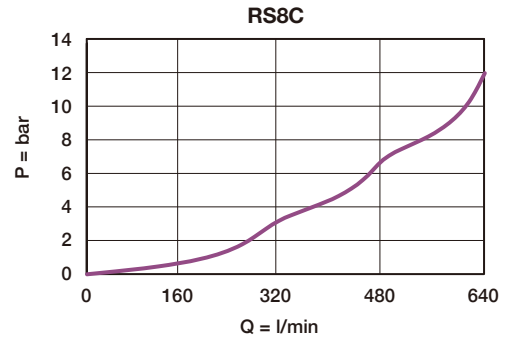
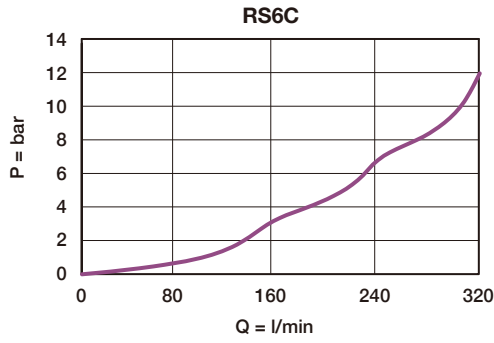
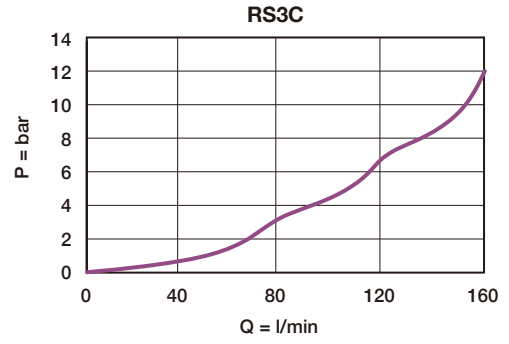
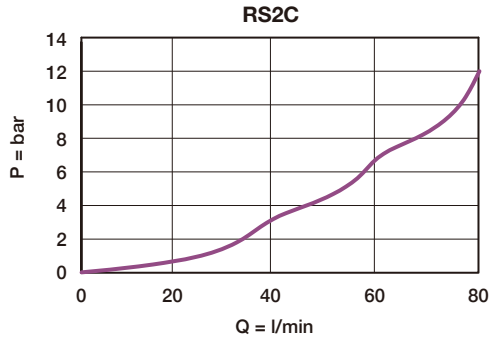

DIMENSION

(UNIT : mm)

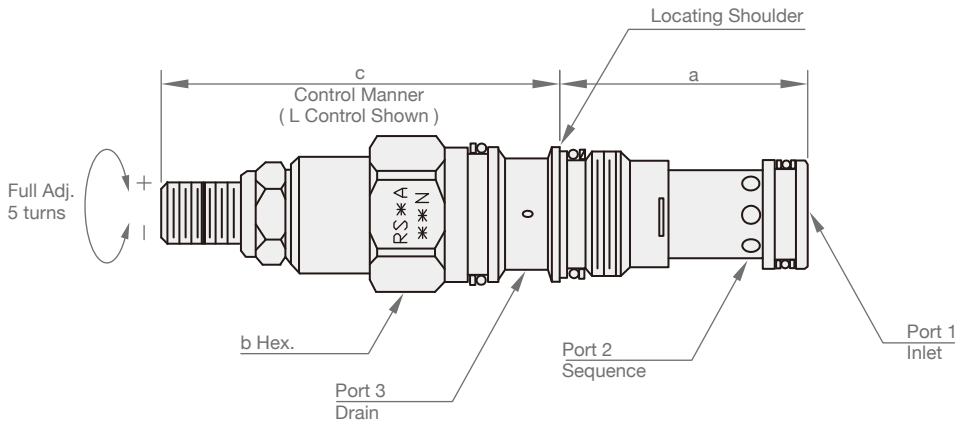

Model	a	b	c	
			L	K
RS2C	34.9	22.2	64	70
RS3C	34.9	28.6	72	78
RS6C	46.0	31.8	84	90
RS8C	63.5	41.3	100	107

PB



SYMBOLS

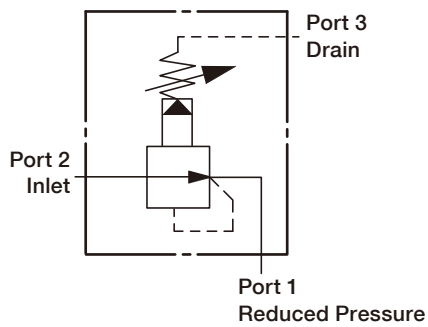

ORDER CODES

PB **2B** - **T11A** - **L** **A** **N**

① ② ③ ④ ⑤ ⑥

① ▶ Model Name	PB	
② ▶ Valve Size	2B, 3B, 6B, 8B	
③ ▶ Cavity	T11A, T2A, T17A, T19A	
④ ▶ Control Manner	L	standard screw adjustment
	K	hand knob with lock knob
⑤ ▶ Adjustable Range	A	7 ~ 210 bar
	B	3.5 ~105 bar
	N	4~55 bar
	W	10~315 bar
⑥ ▶ Material of Seal	N	buna-N
	V	viton

MODEL SPEC.

Model	Cavity	Capacity (l/min)	Max. Pressure (bar)	Installation Torque (Nm)	Operational Temperature	Weight (kg)
PB2B	T11A	40	350	40/50	-35 ~ 100°C (-31 ~ 212°F)	0.17
PB3B	T2A	80	350	60/70		0.30
PB6B	T17A	160	350	200/215		0.64
PB8B	T19A	320	350	465/500		1.43

PERFORMANCE CURVES

► No Load Pressure Drop

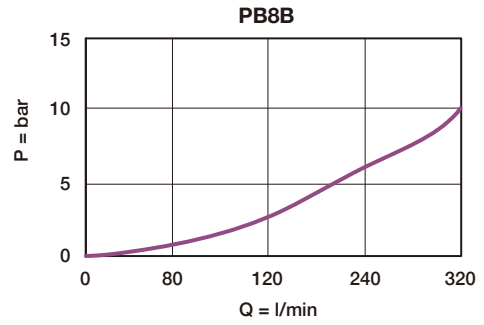
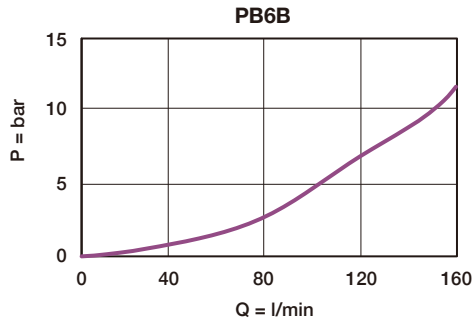
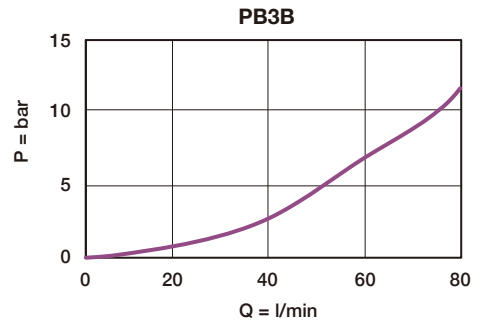
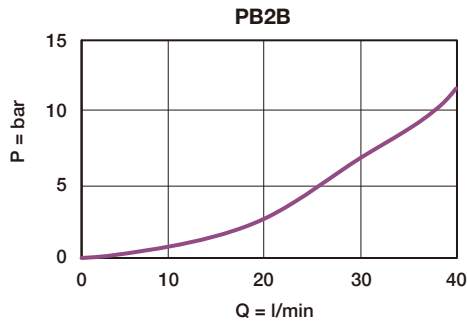

DIMENSION

(UNIT : mm)

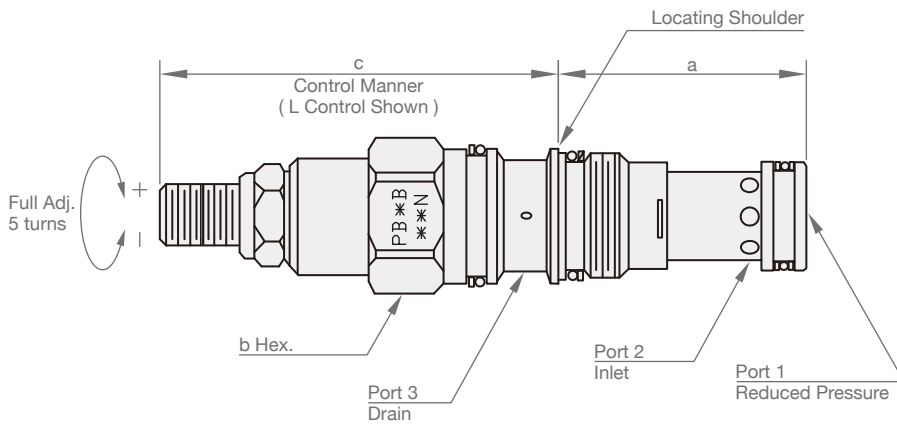

Model	a	b	c	
			L	K
PB2B	34.9	22.2	64	70
PB3B	34.9	28.6	72	78
PB6B	46.0	31.8	84	90
PB8B	63.5	41.3	100	107

PP



SYMBOLS

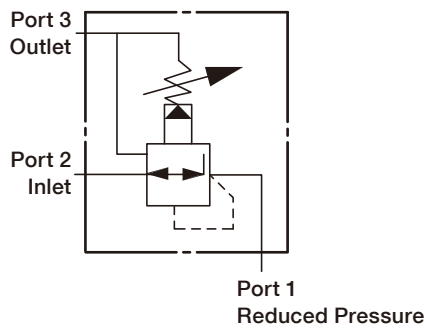

ORDER CODES

PP 2B - T11A - L A N

1 2 3 4 5 6

1	▶ Model Name	PP	
2	▶ Valve Size	2B, 3B, 6B, 8B	
3	▶ Cavity	T11A, T2A, T17A, T19A	
4	▶ Control Manner	L	standard screw adjustment
		K	hand knob with lock knob
5	▶ Adjustable Range	A	7 ~ 210 bar
		B	3.5 ~105 bar
		N	4~55 bar
		W	10~315 bar
6	▶ Material of Seal	N	buna-N
		V	viton

MODEL SPEC.

Model	Cavity	Capacity (l/min)	Max. Pressure (bar)	Installation Torque (Nm)	Operational Temperature	Weight (kg)
PP2B	T11A	40	350	40/50	-35 ~ 100°C (-31 ~ 212°F)	0.17
PP3B	T2A	80	350	60/70		0.30
PP6B	T17A	160	350	200/215		0.64
PP8B	T19A	320	350	465/500		1.43

PERFORMANCE CURVES

► Regulated Pressure

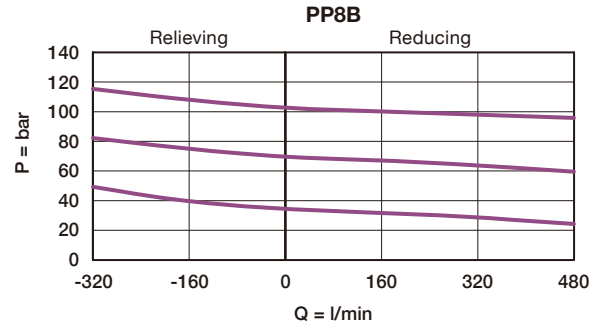
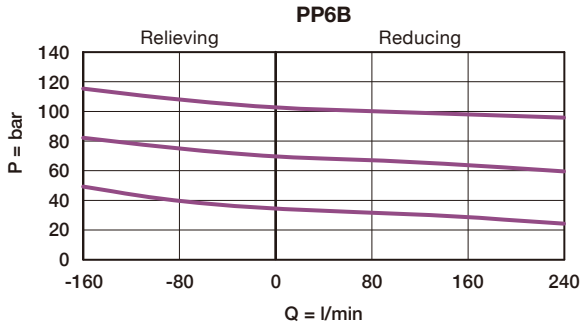
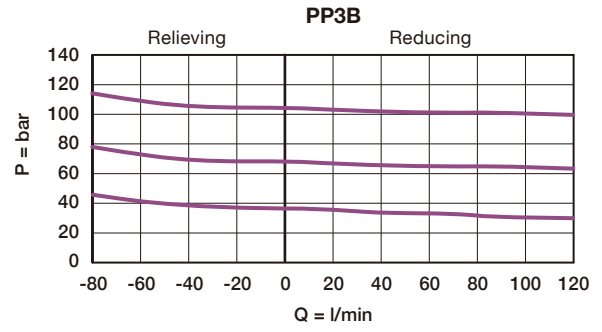
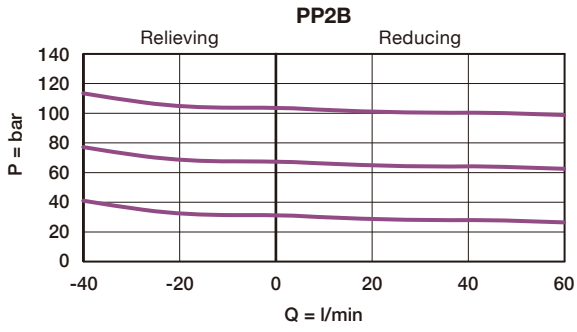

DIMENSION

(UNIT : mm)

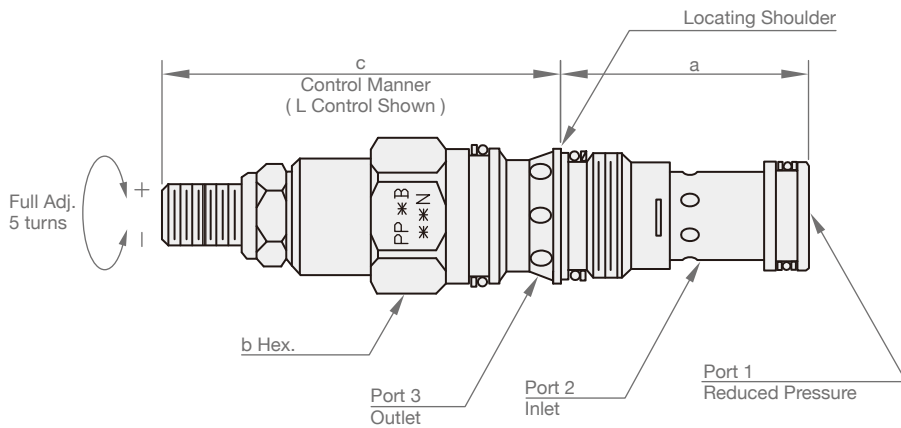

Model	a	b	c	
			L	K
PP2B	34.9	22.2	64	70
PP3B	34.9	28.6	72	78
PP6B	46.0	31.8	84	90
PP8B	63.5	41.3	100	107

PR



SYMBOLS

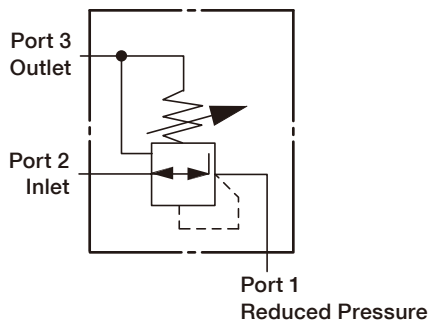

ORDER CODES

PR **2B** - **T11A** - **L** **A** **N**

1 2 3 4 5 6

1	▶ Model Name	PR	
2	▶ Valve Size	2B, 3B, 6B, 8B	
3	▶ Cavity	T11A, T2A, T17A, T19A	
4	▶ Control Manner	L	standard screw adjustment
		K	hand knob with lock knob
5	▶ Adjustable Range	A	35 ~ 210 bar
		B	6.5 ~ 105 bar
		D	5 ~ 55 bar
		E	2 ~ 25 bar
		W	50 ~ 315 bar
6	▶ Material of Seal	N	buna-N
		V	viton

MODEL SPEC.

Model	Cavity	Capacity (l/min)	Max. Pressure (bar)	Installation Torque (Nm)	Operational Temperature	Weight (kg)
PR2B	T11A	40	350	40/50	-35 ~ 100°C (-31 ~ 212°F)	0.20
PR3B	T2A	80	350	60/70		0.36
PR6B	T17A	160	350	200/215		0.76
PR8B	T19A	320	350	465/500		1.58

PERFORMANCE CURVES

► Regulated Pressure

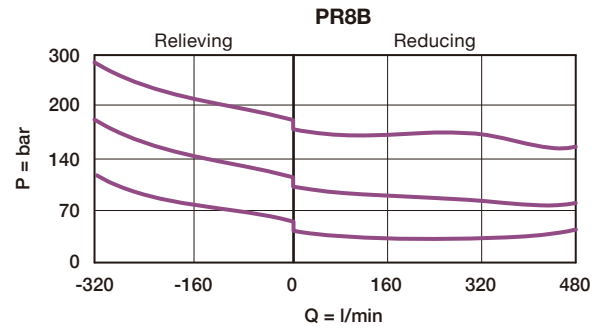
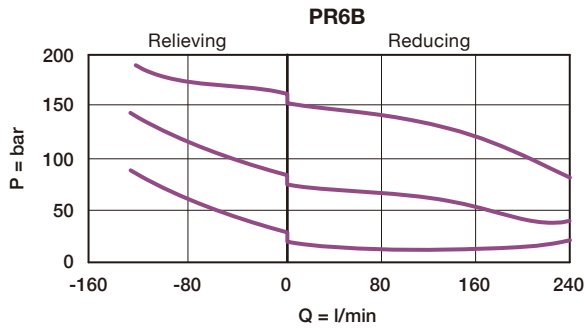
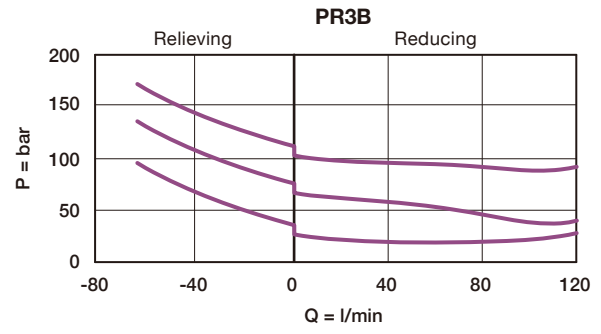
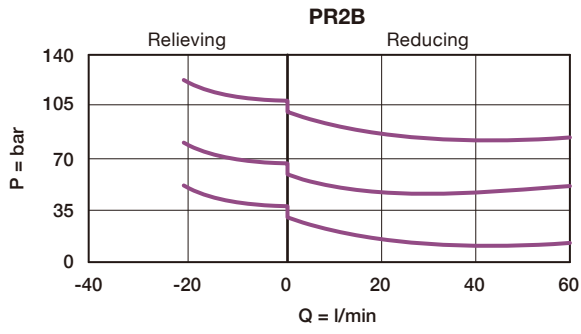

DIMENSION

(UNIT : mm)

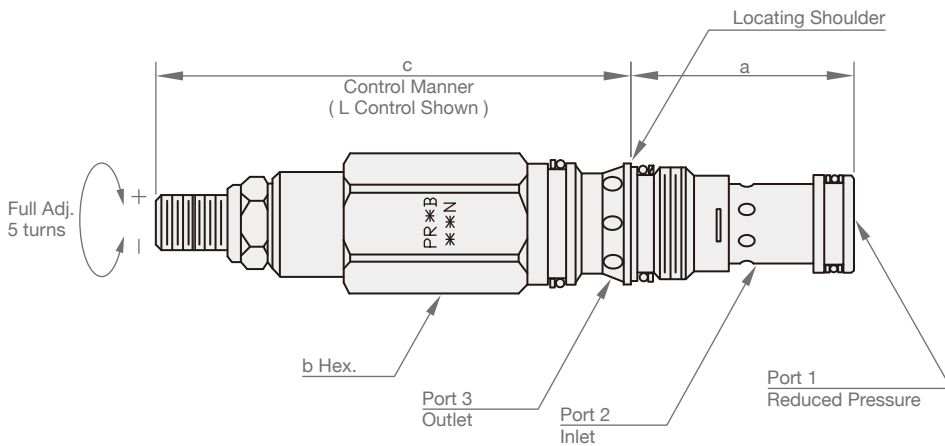

Model	a	b	c	
			L	K
PR2B	34.9	22.2	79	85
PR3B	34.9	28.6	89	96
PR6B	46.0	31.8	100	107
PR8B	63.5	41.3	124	130

NFC



SYMBOLS

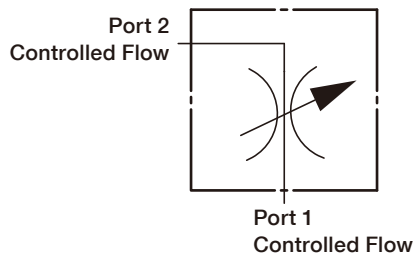

ORDER CODES

NF **2C** - **T13A** - **L** **C** **N**

1 2 3 4 5 6

1	▶ Model Name	NF	
2	▶ Valve Size	2C, 3C, 6C, 8C	
3	▶ Cavity	T13A, T5A, T16A, T18A	
4	▶ Control Manner	L	standard screw adjustment
		K	hand knob with lock knob
5	▶ Max. Orifice	C	T13A : 4.8mm
		A	T5A : 6.3mm
		E	T16A : 9.6mm
		G	T18A : 14.2mm
6	▶ Material of Seal	N	buna-N
		V	viton

MODEL SPEC.

Model	Cavity	Capacity (l/min)	Max. Pressure (bar)	Installation Torque (Nm)	Operational Temperature	Weight (kg)
NF2C	T13A	25	350	40/50	-35 ~ 100°C (-31 ~ 212°F)	0.14
NF3C	T5A	50	350	60/70		0.26
NF6C	T16A	100	350	200/215		0.55
NF8C	T18A	200	350	465/500		1.21

PERFORMANCE CURVES

► Adjustment Sensitivity at 7 bar Differential

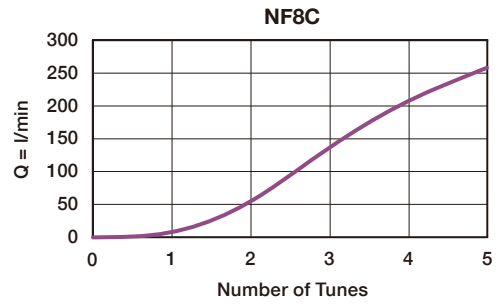
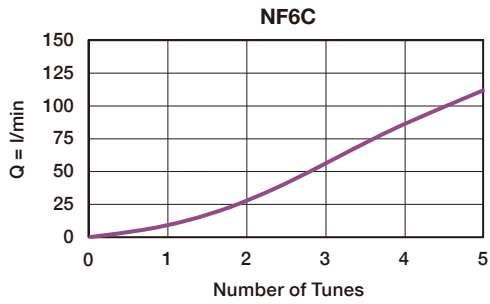
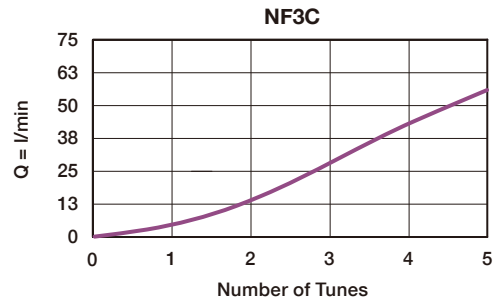
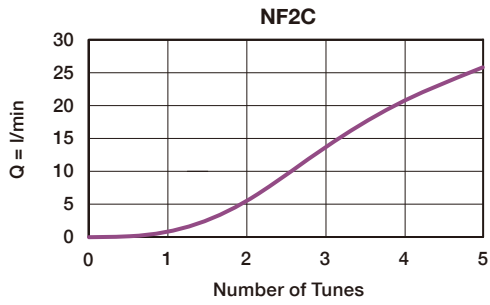

DIMENSION

(UNIT : mm)

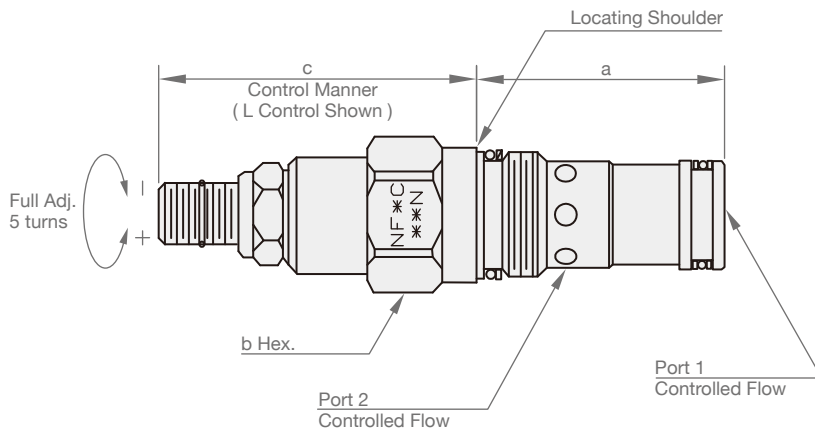

Model	a	b	c	
			L	K
NF2C	34.9	22.2	58	64
NF3C	41.1	28.6	67	73
NF6C	61.9	31.8	73	79
NF8C	79.4	41.3	84	90

NFD



SYMBOLS

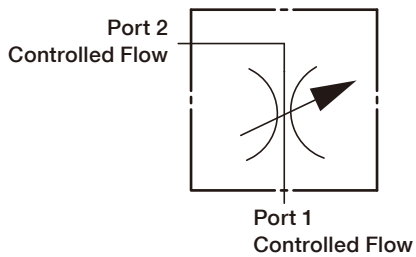

ORDER CODES

NF 2 D - T13A - L F N

1 2 3 4 5 6 7

1	▶ Model Name	NF
2	▶ Valve Size	2, 3, 6, 8
3	▶ Operation	D high capacity
4	▶ Cavity	T13A, T5A, T16A, T18A
5	▶ Control Manner	L standard screw adjustment
		K hand knob with lock knob
6	▶ Max. Orifice	F T13A : 8.4mm
		G T5A : 12.7mm
		H T16A : 17.5mm
		I T18A : 21.6mm
7	▶ Material of Seal	N buna-N
		V viton

MODEL SPEC.

Model	Cavity	Capacity (l/min)	Max. Pressure (bar)	Installation Torque (Nm)	Operational Temperature	Weight (kg)
NF2D	T13A	80	350	40/50	-35 ~ 100°C (-31 ~ 212°F)	0.15
NF3D	T5A	160	350	60/70		0.28
NF6D	T16A	320	350	200/215		0.57
NF8D	T18A	500	350	465/500		1.24

PERFORMANCE CURVES

► Adjustment Sensitivity at 7 bar Differential

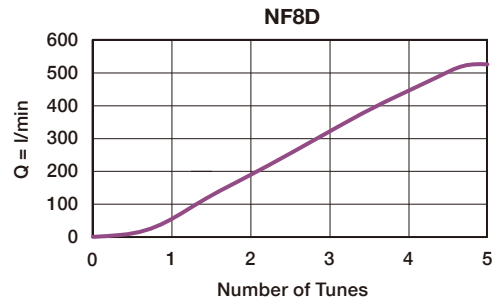
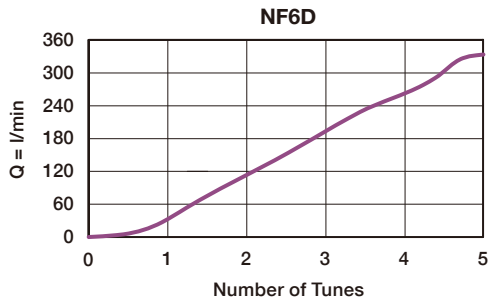
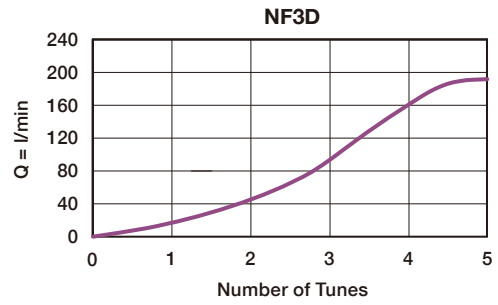
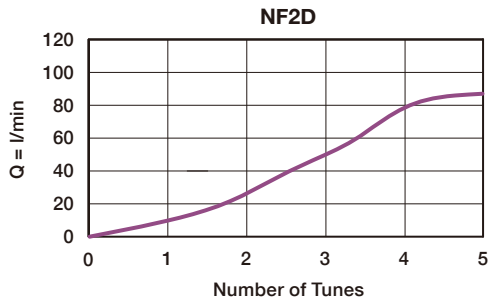

DIMENSION

(UNIT : mm)

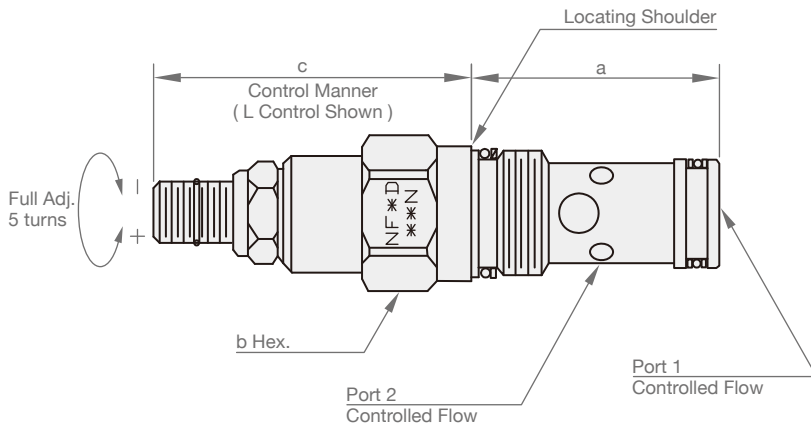

Model	a	b	c	
			L	K
NF2D	34.9	22.2	58	64
NF3D	41.1	28.6	67	73
NF6D	61.9	31.8	73	79
NF8D	79.4	41.3	84	90

NCB



SYMBOLS

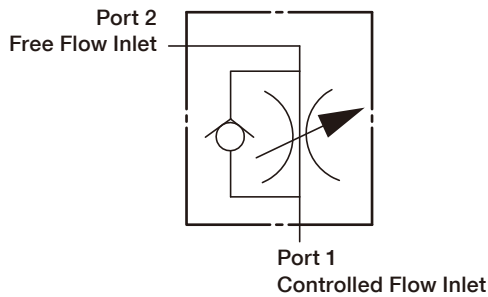

ORDER CODES

NC **2B** - **T13A** - **L** **C** **N**

1 2 3 4 5 6

1	▶ Model Name	NC	
2	▶ Valve Size	2B, 3B, 6B, 8B	
3	▶ Cavity & Max. Orifice	T13A	4.8mm
		T5A	6.3mm
		T16A	9.6mm
		T18A	14.2mm
4	▶ Control Manner	L	standard screw adjustment
		K	hand knob with lock knob
5	▶ Cracking Pressure	A	0.3 bar
		C	2.0 bar
		E	5.0 bar
6	▶ Material of Seal	N	buna-N
		V	viton

MODEL SPEC.

Model	Cavity	Capacity (l/min)	Max. Pressure (bar)	Installation Torque (Nm)	Operational Temperature	Weight (kg)
NC2B	T13A	25	350	40/50	-35 ~ 100°C (-31 ~ 212°F)	0.14
NC3B	T5A	50	350	60/70		0.26
NC6B	T16A	100	350	200/215		0.58
NC8B	T18A	200	350	465/500		1.23

PERFORMANCE CURVES

► Adjustment Sensitivity at 7 bar Differential

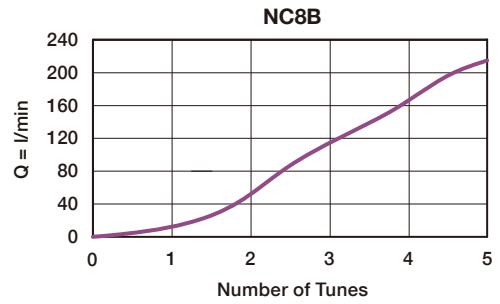
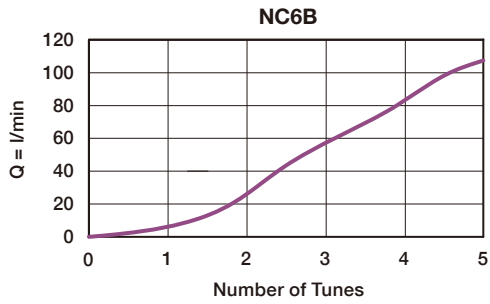
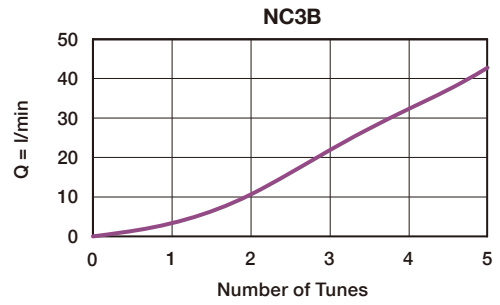
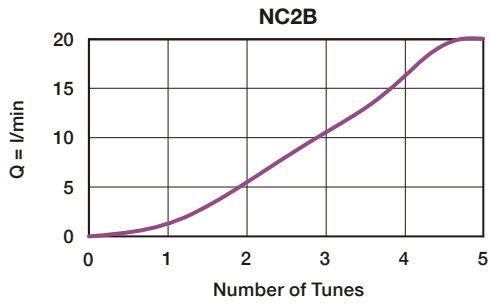

DIMENSION

(UNIT : mm)

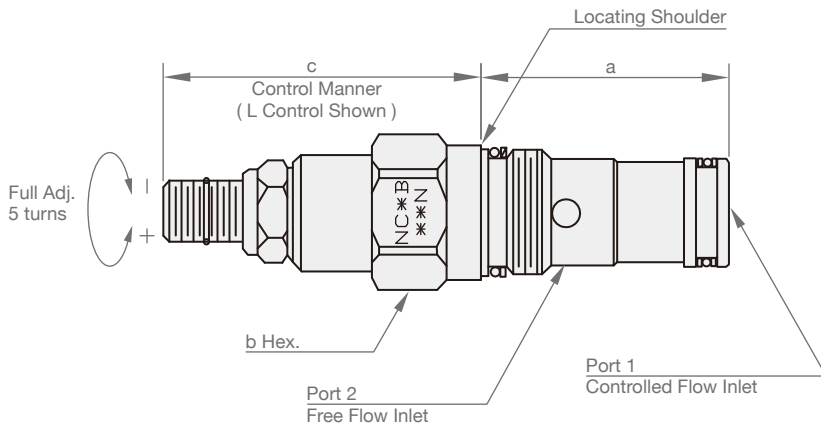

Model	a	b	c	
			L	K
NC2B	34.9	22.2	58	64
NC3B	41.1	28.6	67	73
NC6B	61.9	31.8	73	79
NC8B	79.4	41.3	84	90

FD



SYMBOLS

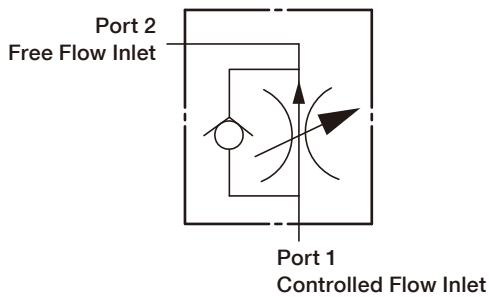

ORDER CODES

FD 2A - T13A - L A N

1 2 3 4 5 6

1	Model Name	FD
2	Valve Size	2A, 3B, 6A, 8A
3	Cavity	T13A, T5A, T16A, T18A
4	Control Manner	L standard screw adjustment
		K hand knob with lock knob
5	Adjustable Range	A 2A : 0.4 ~ 23 l/min 3B : 0.4 ~ 45 l/min 6A : 1.0 ~ 95 l/min 8A : 1.0 ~ 200 l/min
6	Material of Seal	N buna-N
		V viton

MODEL SPEC.

Model	Cavity	Capacity (l/min)	Max. Pressure (bar)	Installation Torque (Nm)	Operational Temperature	Weight (kg)
FD2A	T13A	23	350	40/50	-35 ~ 100°C (-31 ~ 212°F)	0.14
FD3B	T5A	45	350	60/70		0.28
FD6A	T16A	95	350	200/215		0.55
FD8A	T18A	200	350	465/500		1.23

PERFORMANCE CURVES

► Typical Performance

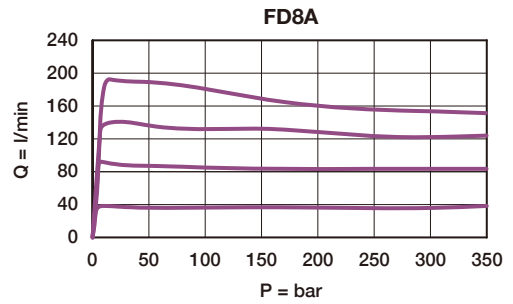
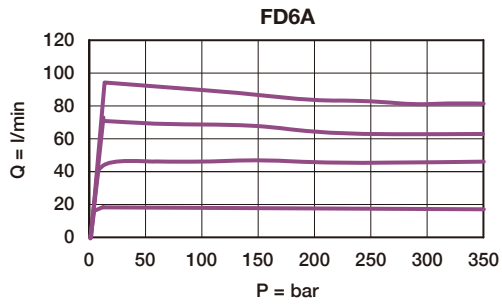
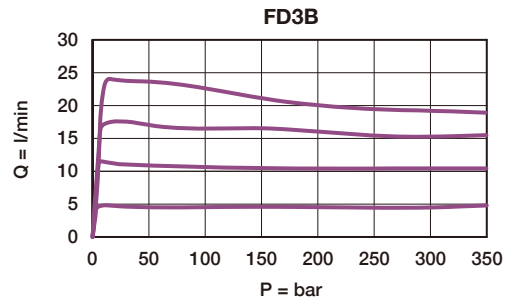
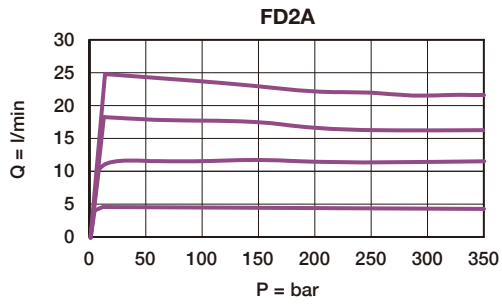

DIMENSION

(UNIT : mm)

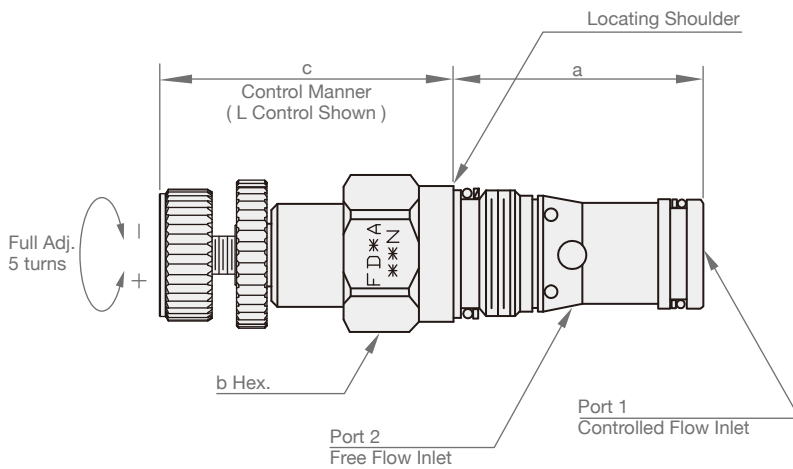

Model	a	b	c	
			L	K
FD2A	34.9	22.2	58	64
FD3B	41.1	28.6	67	73
FD6A	61.9	31.8	73	79
FD8A	79.4	41.3	84	90

LRA



SYMBOLS

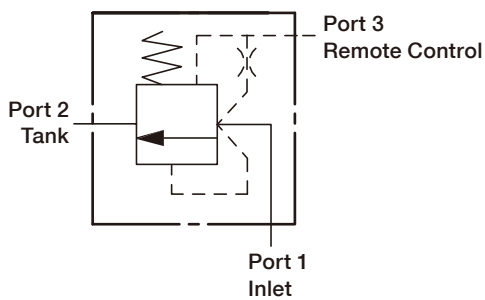

ORDER CODES

LR 2 A - T11A - X D N

1 2 3 4 5 6 7

1	▶ Model Name	LR
2	▶ Valve Size	2, 3, 6, 8
3	▶ Type	A internal pilot
4	▶ Cavity	T11A, T2A, T17A, T19A
5	▶ Control Manner	X unadjustable
		L standard screw adjustment
6	▶ Cracking Pressure	D 3.5 bar
		F 7.0 bar
		G 10.0 bar
7	▶ Material of Seal	N buna-N
		V viton

MODEL SPEC.

Model	Cavity	Capacity (l/min)	Max. Pressure (bar)	Installation Torque (Nm)	Operational Temperature	Weight (kg)
LR2A	T11A	60	350	40/50	-35 ~ 100°C (-31 ~ 212°F)	0.12
LR3A	T2A	120	350	60/70		0.22
LR6A	T17A	240	350	200/215		0.50
LR8A	T19A	480	350	465/500		1.15

PERFORMANCE CURVES

► Typical Pressure Drop

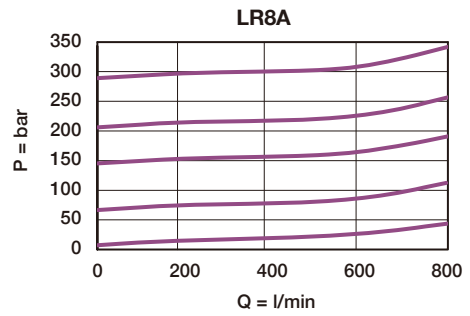
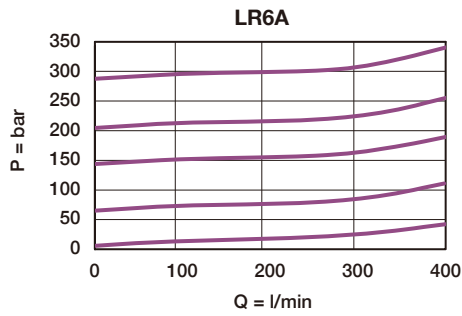
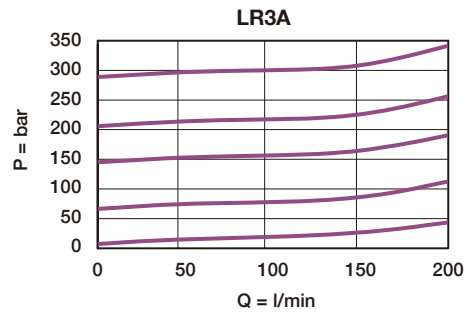
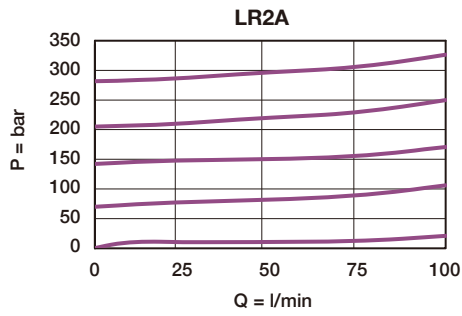

DIMENSION

(UNIT : mm)

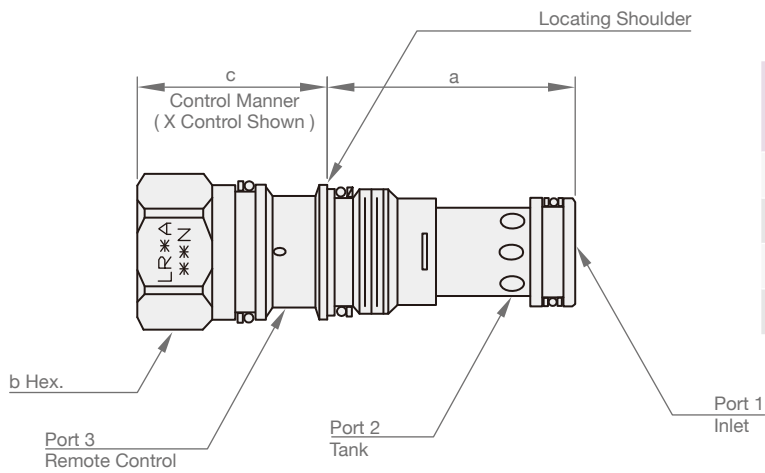

Model	a	b	c	
			X	L
LR2A	34.9	22.2	31	64
LR3A	34.9	28.6	35	72
LR6A	46.0	31.8	46	84
LR8A	63.5	41.3	59	100

LRC



SYMBOLS

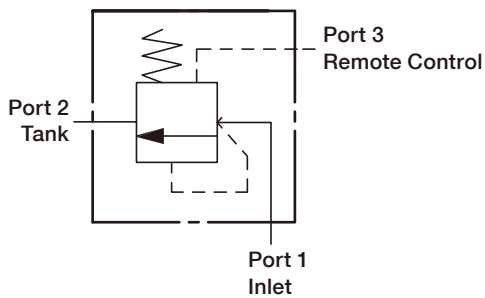

ORDER CODES

LR 2 C - T11A - X D N

1 2 3 4 5 6 7

1	▶ Model Name	LR
2	▶ Valve Size	2, 3, 6, 8
3	▶ Type	C external pilot
4	▶ Cavity	T11A, T2A, T17A, T19A
5	▶ Control Manner	X unadjustable L standard screw adjustment
6	▶ Cracking Pressure	D 3.5 bar F 7.0 bar G 10.0 bar
7	▶ Material of Seal	N buna-N V viton

MODEL SPEC.

Model	Cavity	Capacity (l/min)	Max. Pressure (bar)	Installation Torque (Nm)	Operational Temperature	Weight (kg)
LR2C	T11A	60	350	40/50	-35 ~ 100°C (-31 ~ 212°F)	0.12
LR3C	T2A	120	350	60/70		0.22
LR6C	T17A	240	350	200/215		0.50
LR8C	T19A	480	350	465/500		1.15

PERFORMANCE CURVES

► Typical Pressure Drop

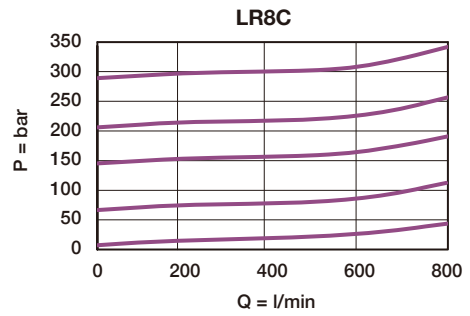
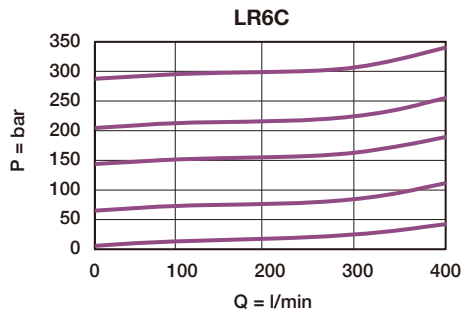
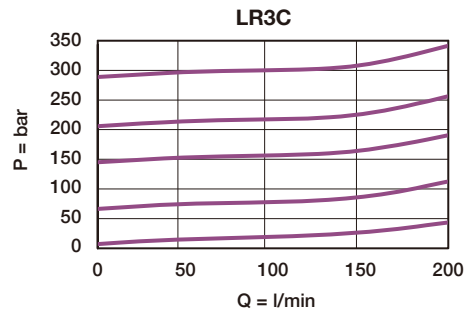
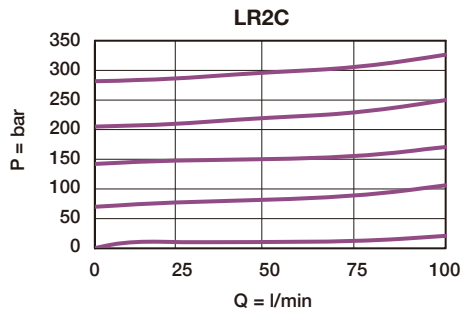

DIMENSION

(UNIT : mm)

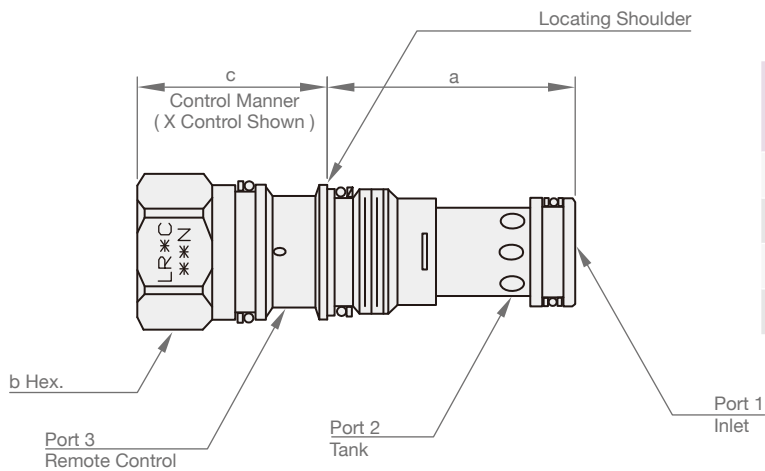

Model	a	b	c	
			X	L
LR2C	34.9	22.2	31	64
LR3C	34.9	28.6	35	72
LR6C	46.0	31.8	46	84
LR8C	63.5	41.3	59	100

CKB



SYMBOLS

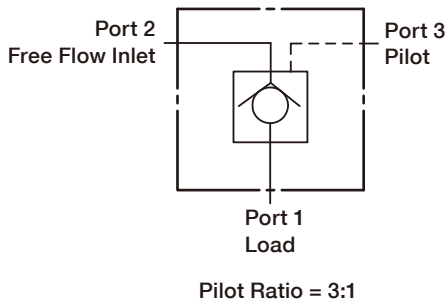

ORDER CODES

CK **2B** - **T11A** - **X** **C** **N**

1 2 3 4 5 6

1	Model Name	CK	
2	Valve Size	2B, 3B, 6B, 8B	
3	Cavity	T11A, T2A, T17A, T19A	
4	Control Manner	X	standard pilot
		L	manual load release
5	Cracking Pressure	A	0.3 bar
		C	2.0 bar
		E	5.0 bar
6	Material of Seal	N	buna-N
		V	viton

MODEL SPEC.

Model	Cavity	Capacity (l/min)	Max. Pressure (bar)	Installation Torque (Nm)	Operational Temperature	Weight (kg)
CK2B	T11A	60	350	40/50	-35 ~ 100°C (-31 ~ 212°F)	0.13
CK3B	T2A	120	350	60/70		0.24
CK6B	T17A	240	350	200/215		0.53
CK8B	T19A	480	350	465/500		1.16

PERFORMANCE CURVES

► Typical Pressure Drop

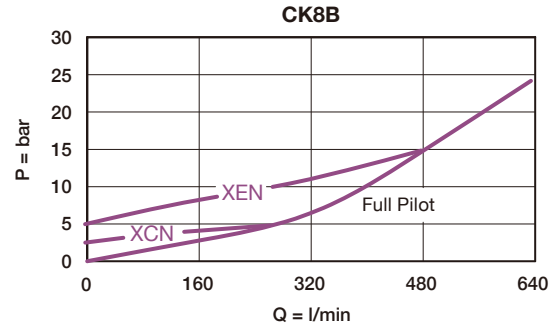
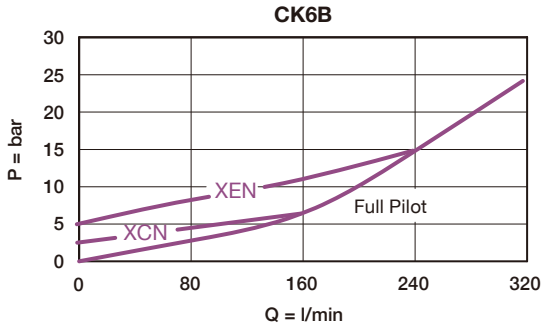
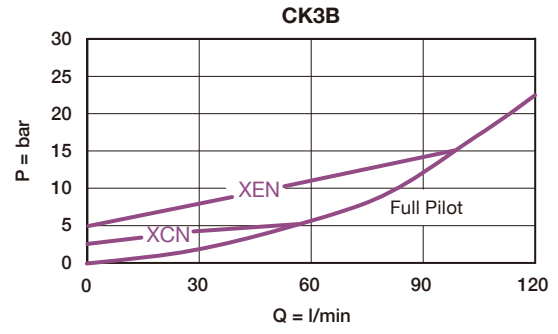
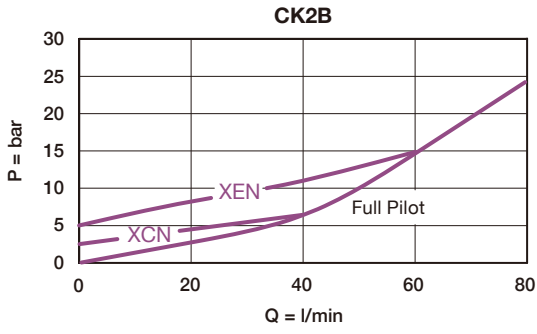

DIMENSION

(UNIT : mm)

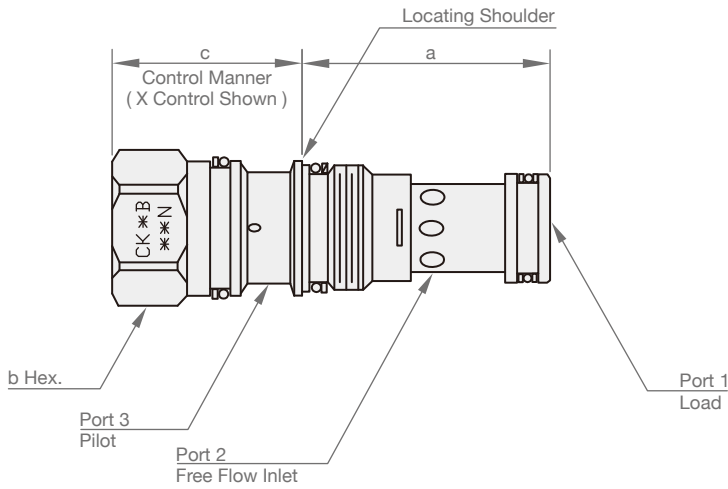

Model	a	b	c	
			X	L
CK2B	34.9	22.2	31	64
CK3B	34.9	28.6	35	72
CK6B	46.0	31.8	46	84
CK8B	63.5	41.3	59	100

CKF



SYMBOLS

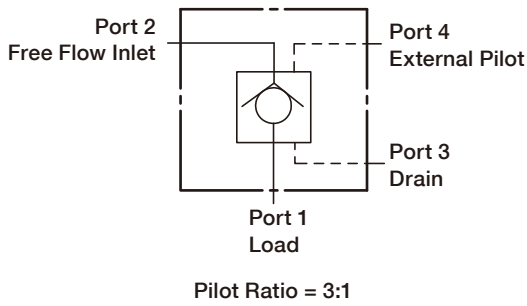

ORDER CODES

CK **2F** - **T11A** - **V** **C** **N**

1 2 3 4 5 6

1	▶ Model Name	CK	
2	▶ Valve Size	2F, 3F, 6F, 8F	
3	▶ Cavity	T11A, T2A, T17A, T19A	
4	▶ Control Manner	V	external pilot port
5	▶ Cracking Pressure	A	0.3 bar
		C	2.0 bar
		E	5.0 bar
6	▶ Material of Seal	N	buna-N
		V	viton

MODEL SPEC.

Model	Cavity	Capacity (l/min)	Max. Pressure (bar)	Installation Torque (Nm)	Operational Temperature	Weight (kg)
CK2F	T11A	60	350	40/50	-35 ~ 100°C (-31 ~ 212°F)	0.13
CK3F	T2A	120	350	60/70		0.24
CK6F	T17A	240	350	200/215		0.53
CK8F	T19A	480	350	465/500		1.16

PERFORMANCE CURVES

► Typical Pressure Drop

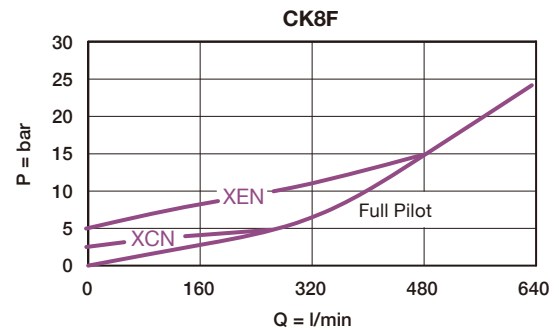
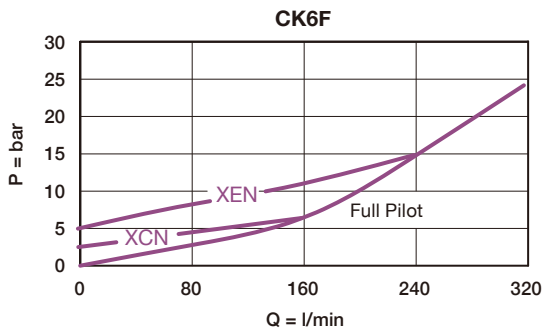
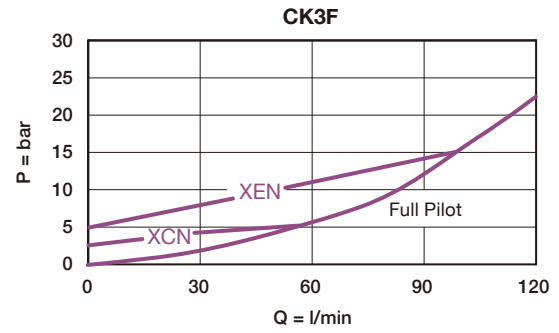
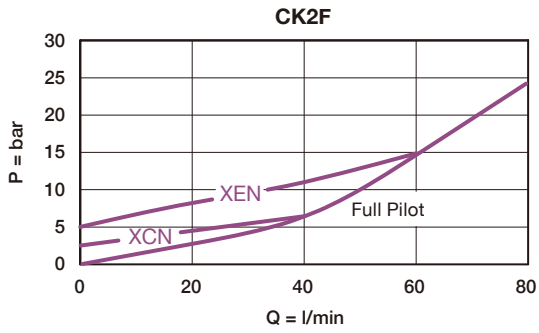

DIMENSION

(UNIT : mm)

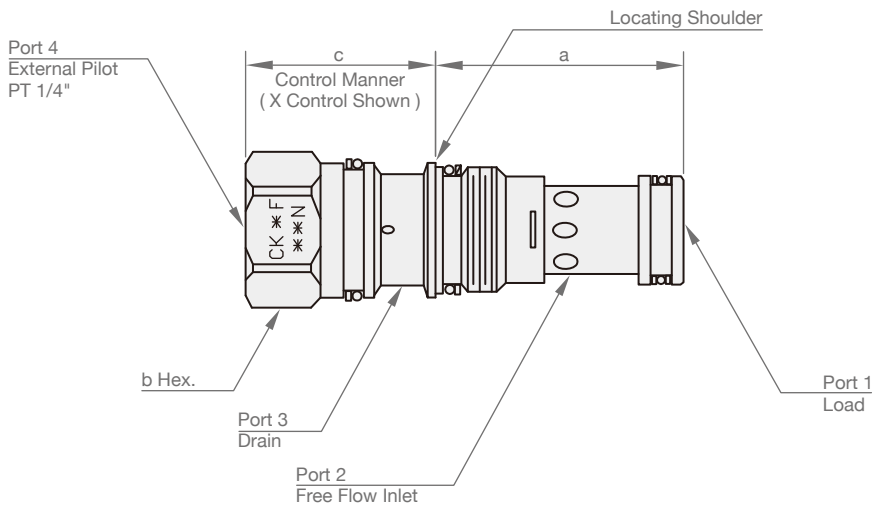

Model	a	b	c	
			X	L
CK2B	34.9	22.2	31	64
CK3B	34.9	28.6	35	72
CK6B	46.0	31.8	46	84
CK8B	63.5	41.3	59	100

CO



SYMBOLS

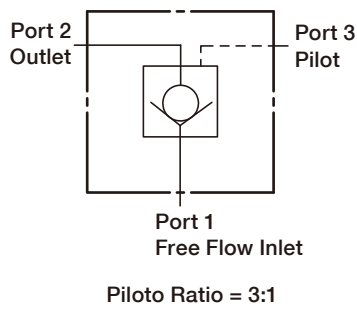

ORDER CODES

CO **2A** - **T11A** - **X** **C** **N**

1 2 3 4 5 6

1	Model Name	CO	
2	Valve Size	1A, 2A, 3A, 6A, 8A	
3	Cavity	T163A, T11A, T2A, T17A, T19A	
4	Control Manner	X	standard pilot
5	Cracking Pressure	A	0.3 bar
		C	2.0 bar
		E	5.0 bar
6	Material of Seal	N	buna-N
		V	viton

MODEL SPEC.

Model	Cavity	Capacity (l/min)	Max. Pressure (bar)	Installation Torque (Nm)	Operational Temperature	Weight (kg)
CO1A	T163A	40	350	30/40	-35 ~ 100°C (-31 ~ 212°F)	0.10
CO2A	T11A	80	350	40/50		0.13
CO3A	T2A	160	350	60/70		0.24
CO6A	T17A	320	350	200/215		0.53
CO8A	T19A	640	350	465/500		1.19

PERFORMANCE CURVES

► Typical Pressure Drop

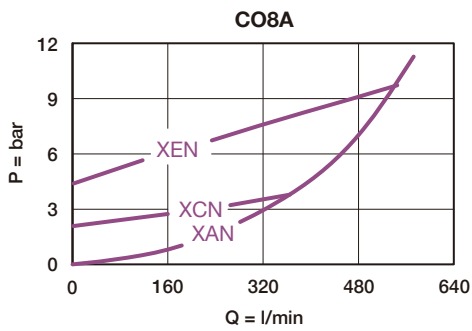
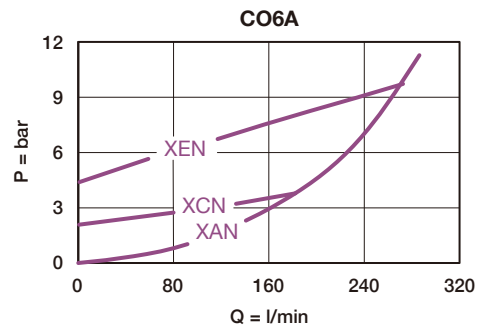
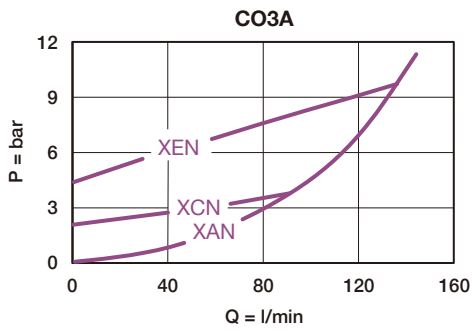
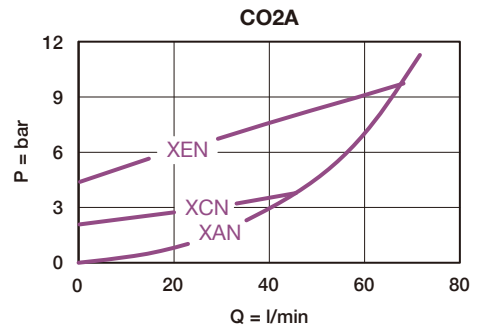
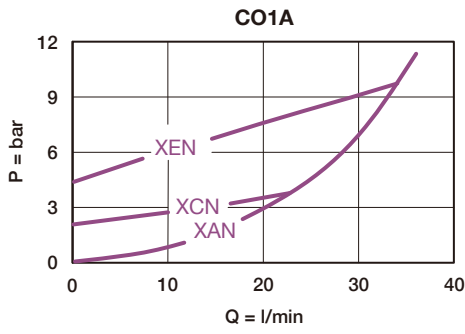

DIMENSION

(UNIT : mm)

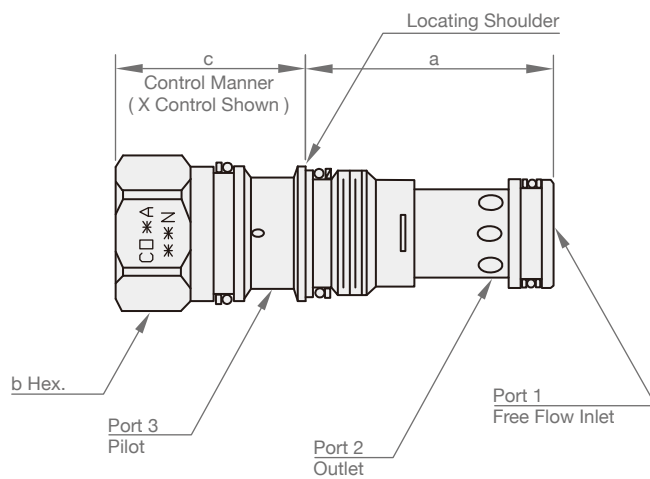

Model	a	b	c
			X
CO1A	31.0	19.1	32
CO2A	34.9	22.2	31
CO3A	34.9	28.6	35
CO6A	46.0	31.8	46
CO8A	63.5	41.3	59

CS



SYMBOLS

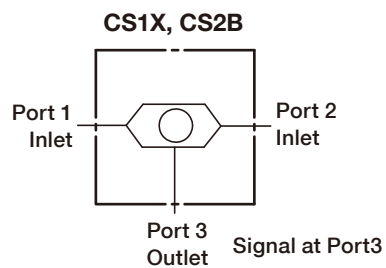
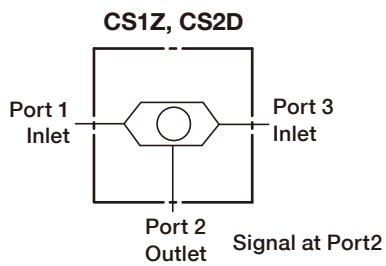

ORDER CODES

CS 2 D - T11A - X X N

1 2 3 4 5 6 7

1	Model Name	CS	
2	Valve Size	1, 2	
3	Operation	CS1Z	T163A, signal at port 2
		CS2D	T11A, signal at port 2
		CS1X	T163A, signal at port 3
		CS2B	T11A, signal at port 3
4	Cavity	T163A, T11A	
5	Control Manner	X	unadjustable
6	Adjustment Range	X	unadjustable
7	Material of Seal	N	buna-N
		V	viton

MODEL SPEC.

Model	Cavity	Capacity (l/min)	Max. Pressure (bar)	Installation Torque (Nm)	Operational Temperature	Weight (kg)
CS1Z	T163A	5	350	30/40	-35 ~ 100°C (-31 ~ 212°F)	0.10
CS2D	T11A	10	350	40/50		0.12
CS1X	T163A	5	350	30/40		0.10
CS2B	T11A	10	350	40/50		0.12

PERFORMANCE CURVES

► Typical Pressure Drop

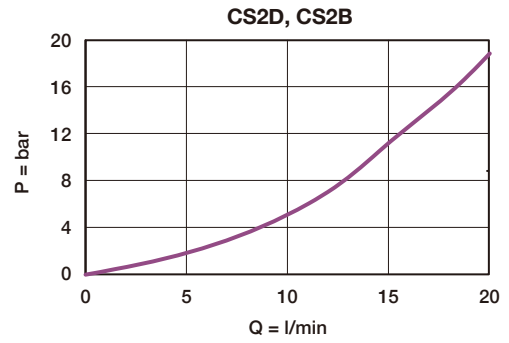
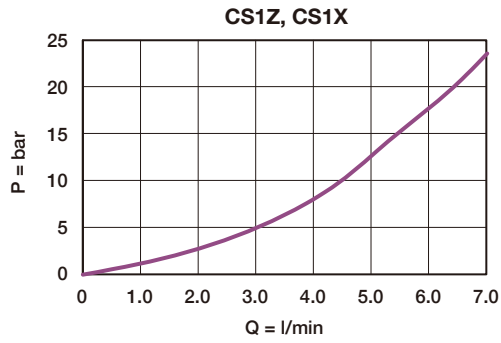

DIMENSION

(UNIT : mm)

► CS1Z, CS2D

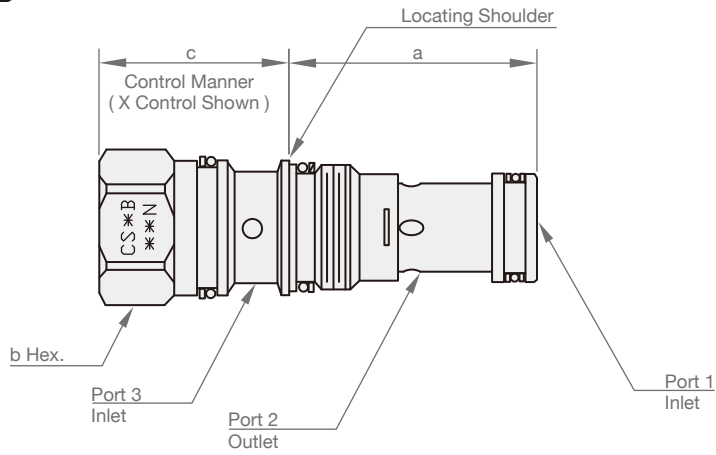

Model	a	b	c
			X
CS1Z	31	19.1	32
CS2D	34.9	22.2	31
CS1X	31	19.1	32
CS2B	34.9	22.2	31

► CS1X, CS2B

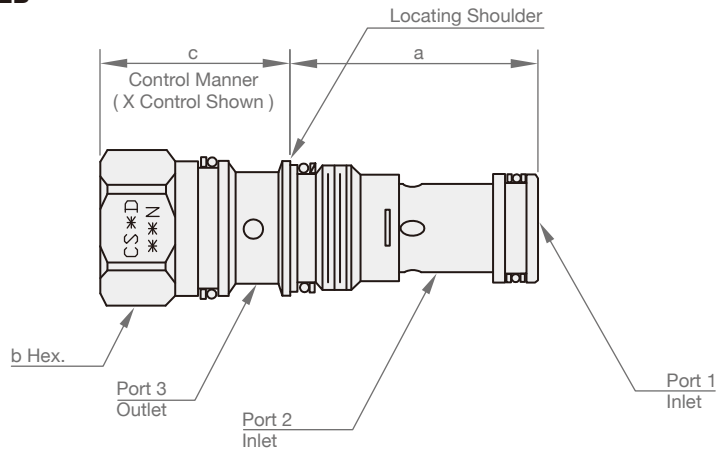

CXA



SYMBOLS

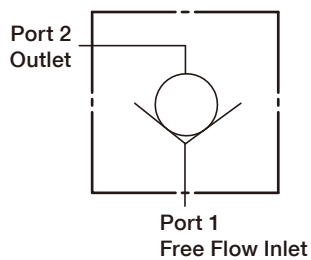

ORDER CODES

CX **2** **A** - **T13A** - **X** **C** **N**

1
2
2
3
4
5
6

1	▶ Model Name	CX	
2	▶ Valve Size	2, 3, 6, 8	
3	▶ Operation	A	Free Flow Port1 to Port2
4	▶ Cavity	T13A, T5A, T16A, T18A	
5	▶ Control Manner	X	unadjustable
6	▶ Cracking Pressure	A	0.3 bar
		B	1.0 bar
		C	2.0 bar
		D	3.5 bar
		E	5.0 bar
7	▶ Material of Seal	N	buna-N
		V	viton

MODEL SPEC.

Model	Cavity	Capacity (l/min)	Max. Pressure (bar)	Installation Torque (Nm)	Operational Temperature	Weight (kg)
CX2A	T13A	80	350	40/50	-35 ~ 100°C (-31 ~ 212°F)	0.12
CX3A	T5A	160	350	60/70		0.18
CX6A	T16A	320	350	200/215		0.42
CX8A	T18A	640	350	465/500		0.93

PERFORMANCE CURVES

► Typical Pressure Drop

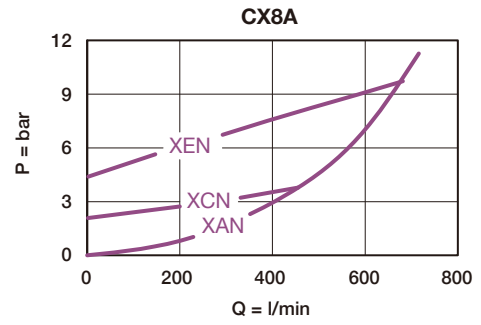
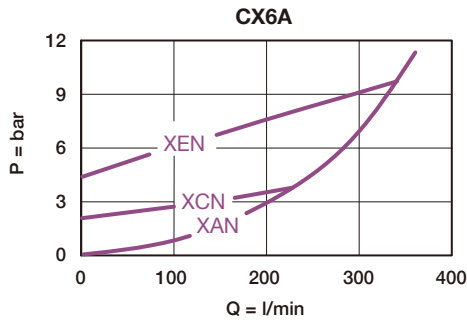
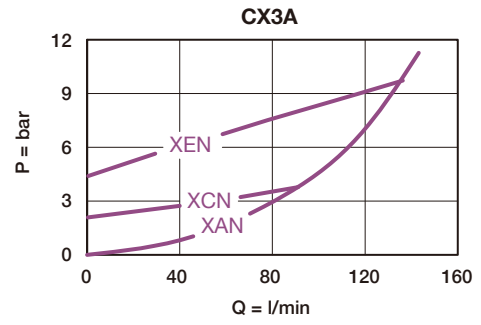
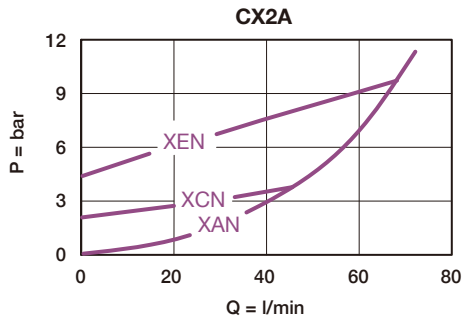

DIMENSION

(UNIT : mm)

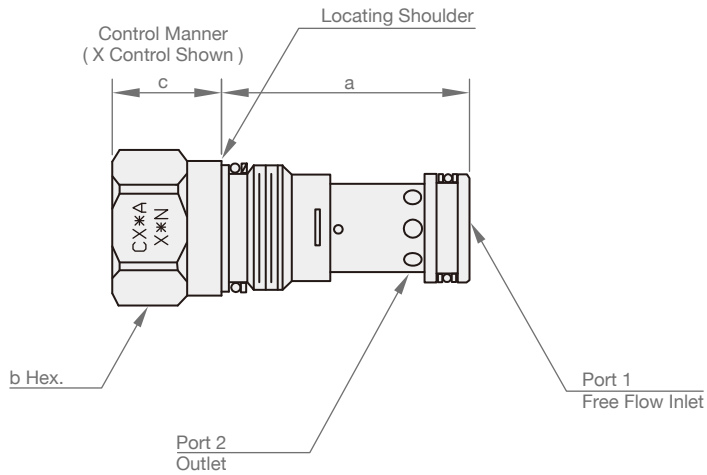

Model	a	b	c
			X
CX2A	34.9	22.2	19
CX3A	41.1	28.6	18
CX6A	61.9	31.8	25
CX8A	79.4	41.3	31

CXD



SYMBOLS

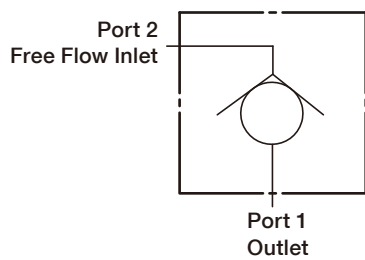

ORDER CODES

CX **2** **D** - **T13A** - **X** **C** **N**

1 2 2 3 4 5 6

1	▶ Model Name	CX
2	▶ Valve Size	2, 3, 6, 8
3	▶ Operation	D Free Flow Por2 to Port1
4	▶ Cavity	T13A, T5A, T16A, T18A
5	▶ Control Manner	X unadjustable
6	▶ Cracking Pressure	A 0.3 bar
		B 1.0 bar
		C 2.0 bar
		D 3.5 bar
		E 5.0 bar
7	▶ Material of Seal	N buna-N
		V viton

MODEL SPEC.

Model	Cavity	Capacity (l/min)	Max. Pressure (bar)	Installation Torque (Nm)	Operational Temperature	Weight (kg)
CX2D	T13A	60	350	40/50	-35 ~ 100°C (-31 ~ 212°F)	0.12
CX3D	T5A	120	350	60/70		0.18
CX6D	T16A	240	350	200/215		0.42
CX8D	T18A	480	350	465/500		0.93

PERFORMANCE CURVES

► Typical Pressure Drop

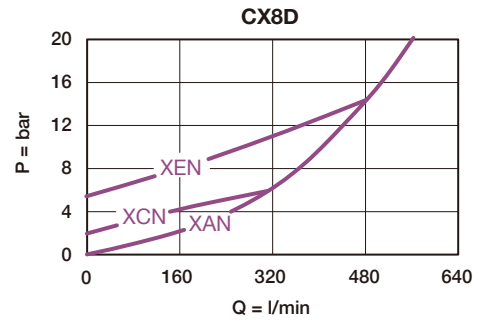
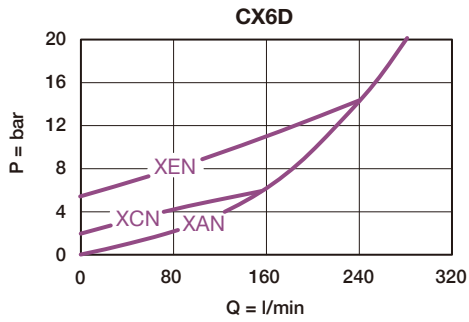
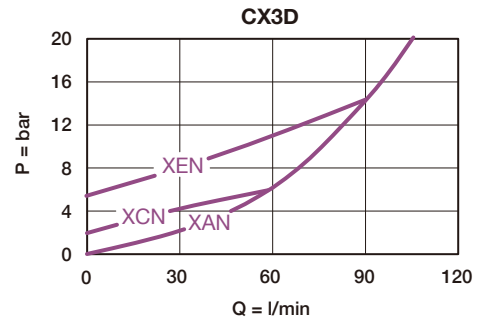
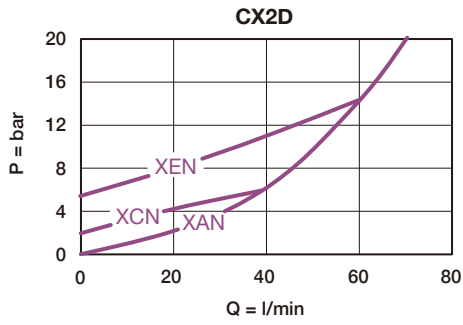

DIMENSION

(UNIT : mm)

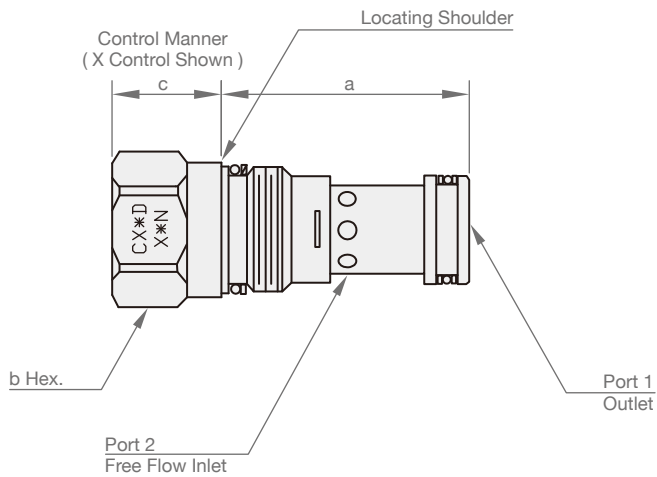

Model	a	b	c
			X
CX2D	34.9	22.2	19
CX3D	41.1	28.6	18
CX6D	61.9	31.8	25
CX8D	79.4	41.3	31

CBA



SYMBOLS

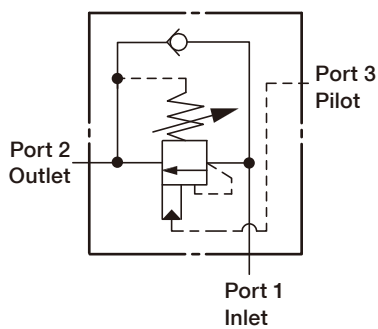

ORDER CODES

CB 2 A - T11A - L I N

1 2 3 4 5 6 7

1	Model Name	CB
2	Valve Size	2, 3, 6, 8
3	Pilot Ratio	A 3:1
4	Cavity	T11A, T2A, T17A, T19A
5	Control Manner	L standard screw adjustment
6	Adjustable Range	H 70 ~ 280 bar, w/1.7 bar check, 210 bar initially setting
		I 25 ~ 105 bar, w/1.7 bar check, 70 bar initially setting
		A 70 ~ 280 bar, w/0.3 bar check, 210 bar initially setting
		B 25 ~ 105 bar, w/0.3 bar check, 70 bar initially setting
7	Material of Seal	N buna-N
		V viton

MODEL SPEC.

Model	Cavity	Capacity (l/min)	Max. Pressure (bar)	Installation Torque (Nm)	Operational Temperature	Weight (kg)
CB2A	T11A	60	350	40/50	-35 ~ 100°C (-31 ~ 212°F)	0.17
CB3A	T2A	120	350	60/70		0.30
CB6A	T17A	240	350	200/215		0.64
CB8A	T19A	480	350	465/500		1.47

PERFORMANCE CURVES

Free Flow and Piloted Open Pressure Drop

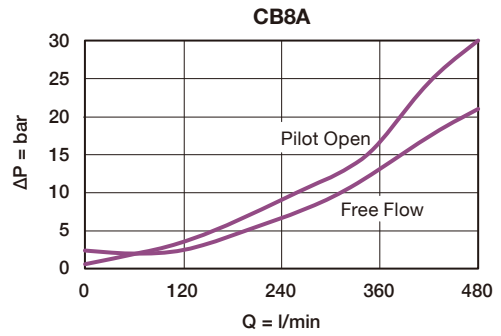
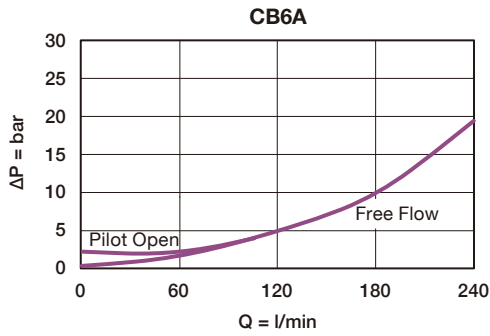
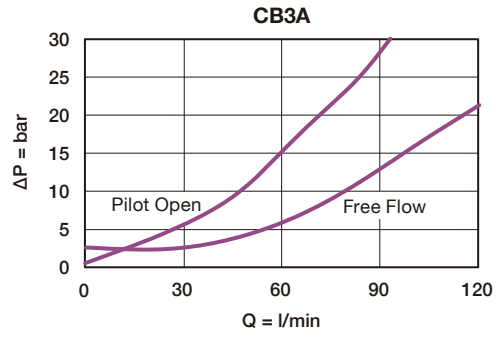
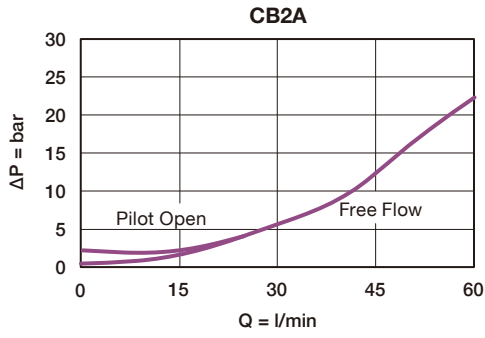

DIMENSION

(UNIT : mm)

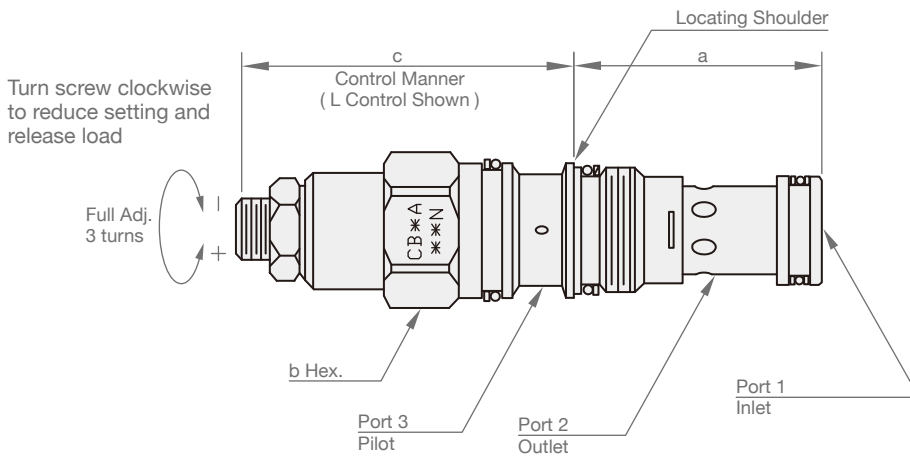

Model	a	b	c
			L
CB2A	34.9	22.2	50
CB3A	34.9	28.6	61
CB6A	46.0	31.8	70
CB8A	63.5	41.3	90

CBG



SYMBOLS

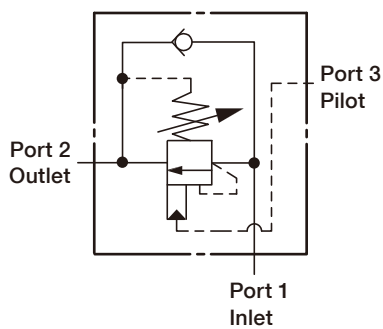

ORDER CODES

CB 2 G - T11A - L K N

1 2 3 4 5 6 7

1	Model Name	CB
2	Valve Size	2, 3, 6, 8
3	Pilot Ratio	G 4.5:1
4	Cavity	T11A, T2A, T17A, T19A
5	Control Manner	L standard screw adjustment
6	Adjustable Range	J 140 ~ 350 bar, w/1.7 bar check, 210 bar initially setting
		K 70 ~ 175 bar, w/1.7 bar check, 140 bar initially setting
		C 140 ~ 350 bar, w/0.3 bar check, 210 bar initially setting
		D 70 ~ 175 bar, w/0.3 bar check, 140 bar initially setting
7	Material of Seal	N buna-N
		V viton

MODEL SPEC.

Model	Cavity	Capacity (l/min)	Max. Pressure (bar)	Installation Torque (Nm)	Operational Temperature	Weight (kg)
CB2G	T11A	60	350	40/50	-35 ~ 100°C (-31 ~ 212°F)	0.17
CB3G	T2A	120	350	60/70		0.30
CB6G	T17A	240	350	200/215		0.64
CB8G	T19A	480	350	465/500		1.47

PERFORMANCE CURVES

Free Flow and Piloted Open Pressure Drop

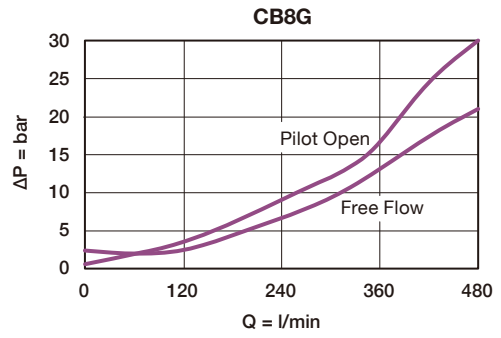
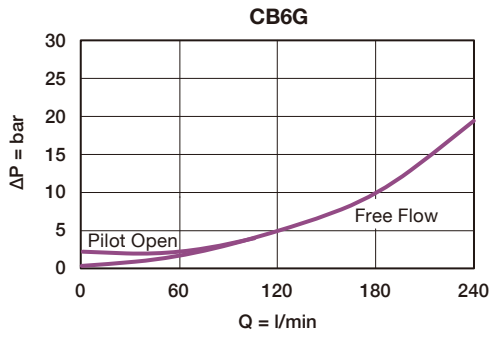
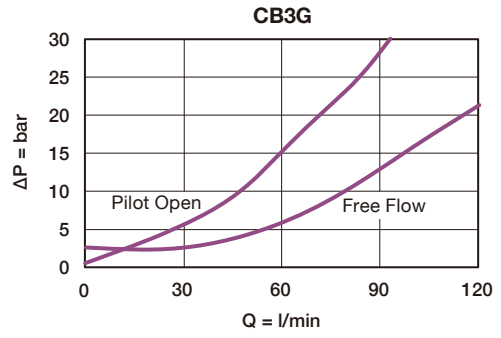
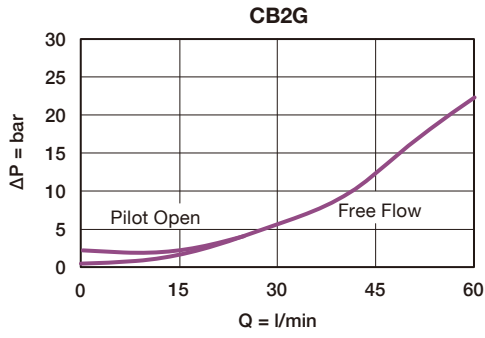

DIMENSION

(UNIT : mm)

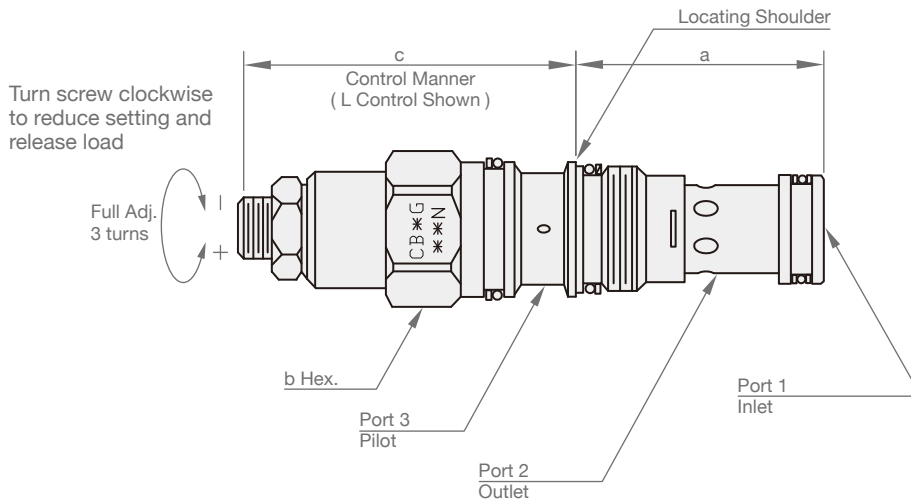

Model	a	b	c
			L
CB2G	34.9	22.2	50
CB3G	34.9	28.6	61
CB6G	46.0	31.8	70
CB8G	63.5	41.3	90

CBH



SYMBOLS

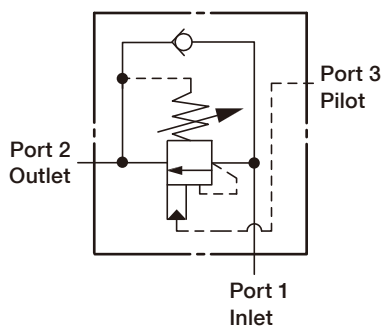

ORDER CODES

CB 2 H - T11A - L K N

1 2 3 4 5 6 7

1	▶ Model Name	CB	
2	▶ Valve Size	2, 3, 6, 8	
3	▶ Pilot Ratio	H	10:1
4	▶ Cavity	T11A, T2A, T17A, T19A	
5	▶ Control Manner	L	standard screw adjustment
6	▶ Adjustable Range	J	140 ~ 350 bar, w/1.7 bar check, 210 bar initially setting
		K	70 ~ 175 bar, w/1.7 bar check, 140 bar initially setting
		C	140 ~ 350 bar, w/0.3 bar check, 210 bar initially setting
7	▶ Material of Seal	D	70 ~ 175 bar, w/0.3 bar check, 140 bar initially setting
		N	buna-N
		V	viton

MODEL SPEC.

Model	Cavity	Capacity (l/min)	Max. Pressure (bar)	Installation Torque (Nm)	Operational Temperature	Weight (kg)
CB2H	T11A	60	350	40/50	-35 ~ 100°C (-31 ~ 212°F)	0.17
CB3H	T2A	120	350	60/70		0.30
CB6H	T17A	240	350	200/215		0.64
CB8H	T19A	480	350	465/500		1.47

PERFORMANCE CURVES

Free Flow and Piloted Open Pressure Drop

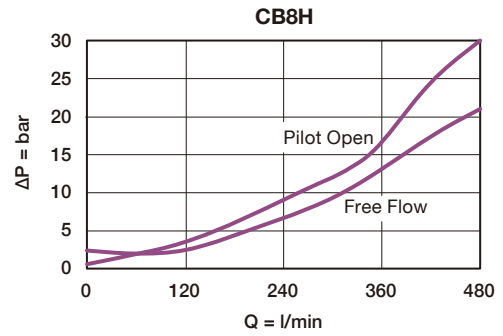
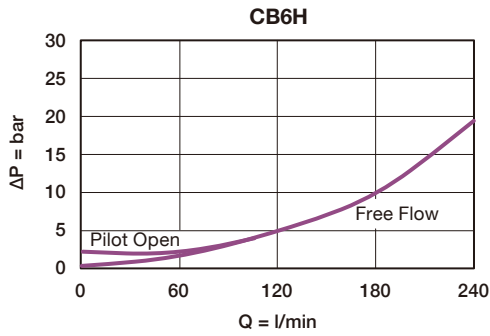
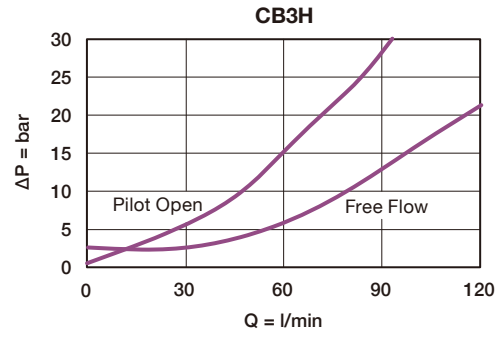
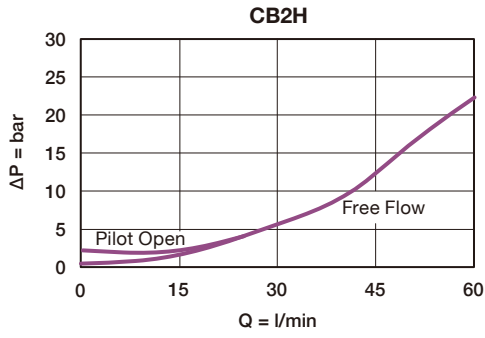

DIMENSION

(UNIT : mm)

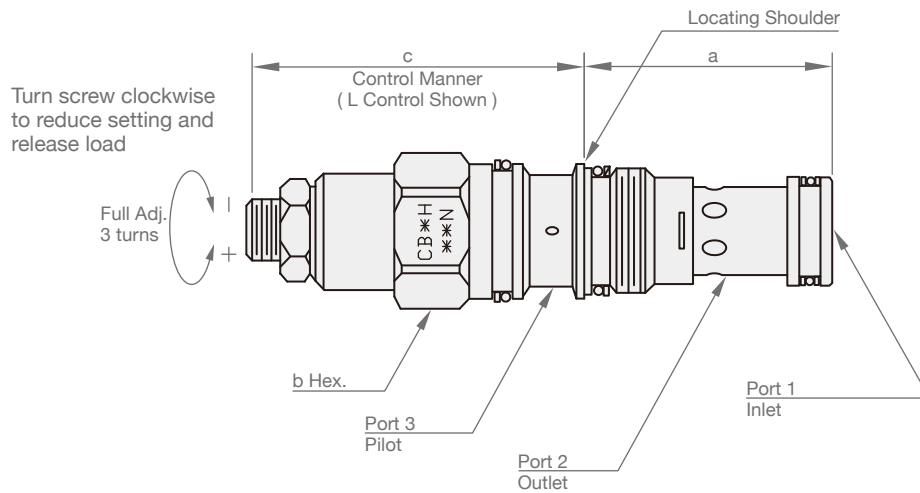

Model	a	b	c
			L
CB2H	34.9	22.2	50
CB3H	34.9	28.6	61
CB6H	46.0	31.8	70
CB8H	63.5	41.3	90

CBC



SYMBOLS

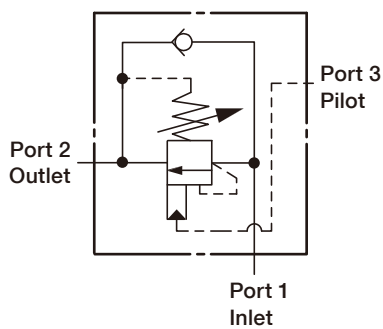

ORDER CODES

CB 2 C - T11A - L I N

1 2 3 4 5 6 7

1	Model Name	CB	
2	Valve Size	2, 3, 6	
3	Pilot Ratio	C	3:1
4	Cavity	T11A, T2A, T17A	
5	Control Manner	L	standard screw adjustment
6	Adjustable Range	H	70 ~ 280 bar, w/1.7 bar check, 210 bar initially setting
		I	25 ~ 105 bar, w/1.7 bar check, 70 bar initially setting
		A	70 ~ 280 bar, w/0.3 bar check, 210 bar initially setting
		B	25 ~ 105 bar, w/0.3 bar check, 70 bar initially setting
7	Material of Seal	N	buna-N
		V	viton

MODEL SPEC.

Model	Cavity	Capacity (l/min)	Max. Pressure (bar)	Installation Torque (Nm)	Operational Temperature	Weight (kg)
CB2C	T11A	40	350	40/50	-35 ~ 100°C (-31 ~ 212°F)	0.17
CB3C	T2A	80	350	60/70		0.30
CB6C	T17A	160	350	200/215		0.64

PERFORMANCE CURVES

Free Flow and Piloted Open Pressure Drop

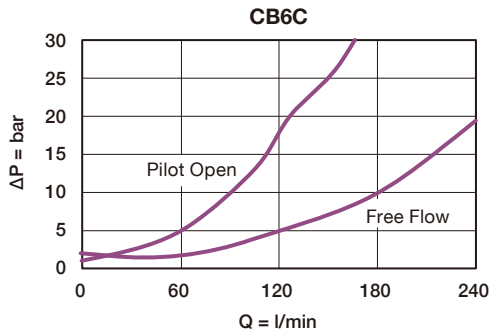
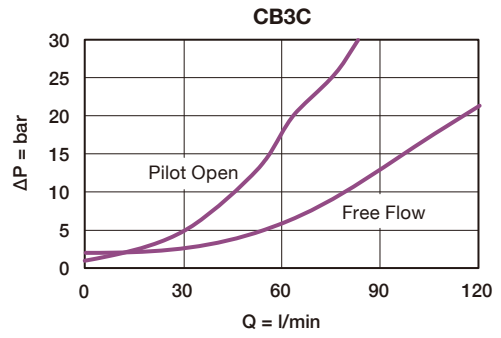
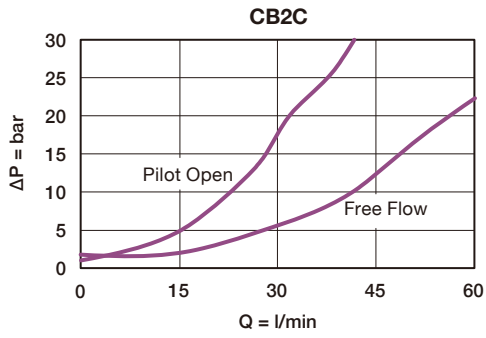

DIMENSION

(UNIT : mm)

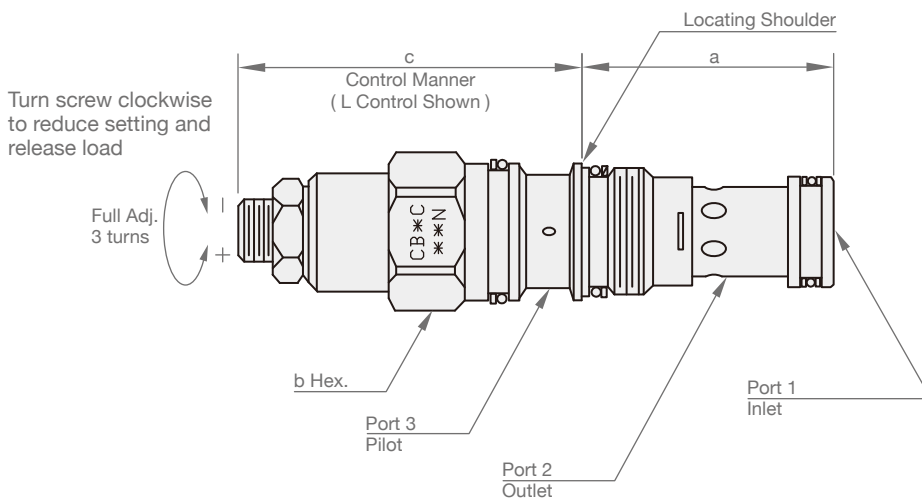

Model	a	b	c
			L
CB2C	34.9	22.2	50
CB3C	34.9	28.6	61
CB6C	46.0	31.8	70

CBD



SYMBOLS

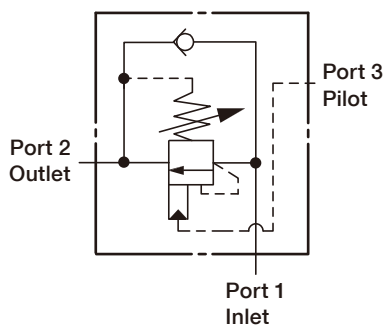

ORDER CODES

CB 2 D - T11A - L J N

1 2 3 4 5 6 7

1	Model Name	CB	
2	Valve Size	2, 3, 6	
3	Pilot Ratio	D	4.5:1
4	Cavity	T11A, T2A, T17A	
5	Control Manner	L	standard screw adjustment
6	Adjustable Range	J	140 ~ 350 bar, w/1.7 bar check, 210 bar initially setting
		K	70 ~ 175 bar, w/1.7 bar check, 140 bar initially setting
		C	140 ~ 350 bar, w/0.3 bar check, 210 bar initially setting
		D	70 ~ 175 bar, w/0.3 bar check, 140 bar initially setting
7	Material of Seal	N	buna-N
		V	viton

MODEL SPEC.

Model	Cavity	Capacity (l/min)	Max. Pressure (bar)	Installation Torque (Nm)	Operational Temperature	Weight (kg)
CB2D	T11A	40	350	40/50	-35 ~ 100°C (-31 ~ 212°F)	0.17
CB3D	T2A	80	350	60/70		0.30
CB6D	T17A	160	350	200/215		0.64

PERFORMANCE CURVES

Free Flow and Piloted Open Pressure Drop

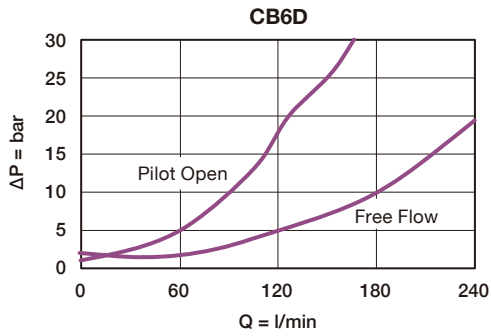
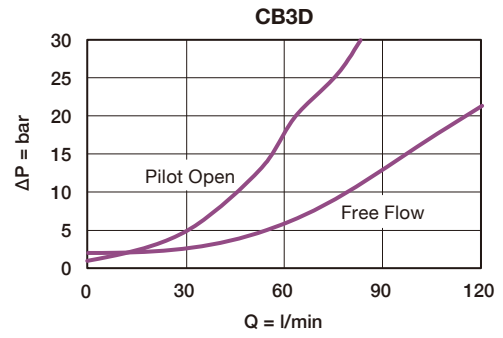
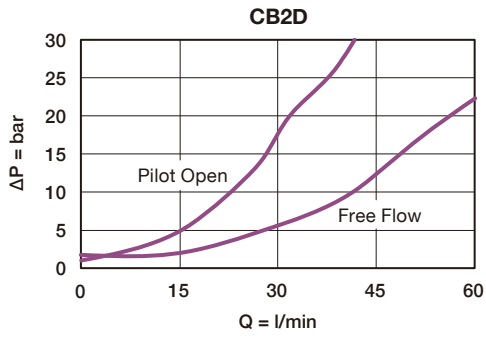

DIMENSION

(UNIT : mm)

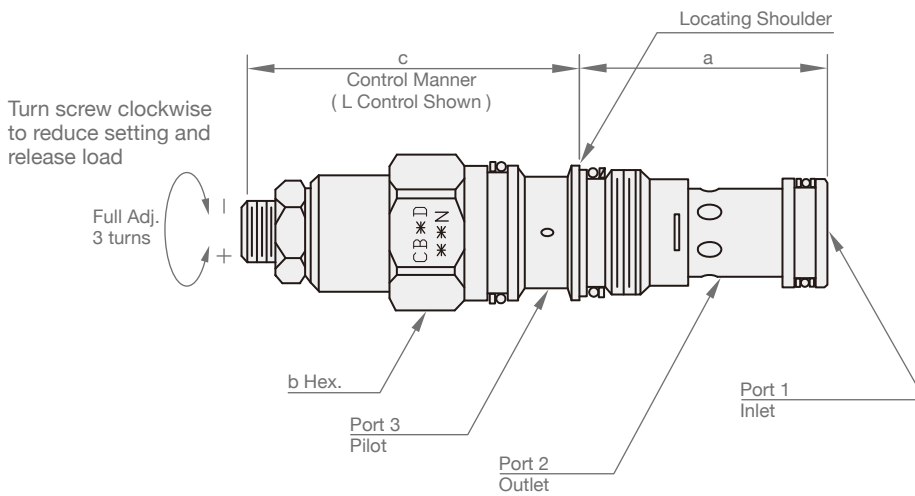

Model	a	b	c
			L
CB2D	34.9	22.2	50
CB3D	34.9	28.6	61
CB6D	46.0	31.8	70

CBE



SYMBOLS

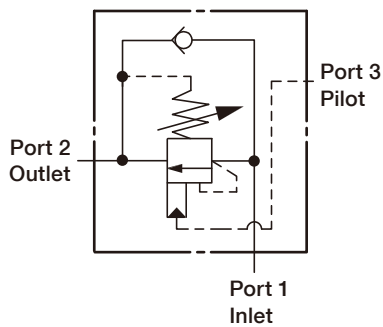

ORDER CODES

CB 2 E - T11A - L I N

1 2 3 4 5 6 7

1	Model Name	CB	
2	Valve Size	2, 3, 6, 8	
3	Pilot Ratio	E	3:1
4	Cavity	T11A, T2A, T17A, T19A	
5	Control Manner	L	standard screw adjustment
6	Adjustable Range	H	70 ~ 280 bar, w/1.7 bar check, 210 bar initially setting
		I	25 ~ 105 bar, w/1.7 bar check, 70 bar initially setting
		A	70 ~ 280 bar, w/0.3 bar check, 210 bar initially setting
7	Material of Seal	B	25 ~ 105 bar, w/0.3 bar check, 70 bar initially setting
		N	buna-N
		V	viton

MODEL SPEC.

Model	Cavity	Capacity (l/min)	Max. Pressure (bar)	Installation Torque (Nm)	Operational Temperature	Weight (kg)
CB2E	T11A	15	350	40/50	-35 ~ 100°C (-31 ~ 212°F)	0.17
CB3E	T2A	30	350	60/70		0.30
CB6E	T17A	60	350	200/215		0.64
CB8E	T19A	80	350	465/500		1.47

PERFORMANCE CURVES

Free Flow and Piloted Open Pressure Drop

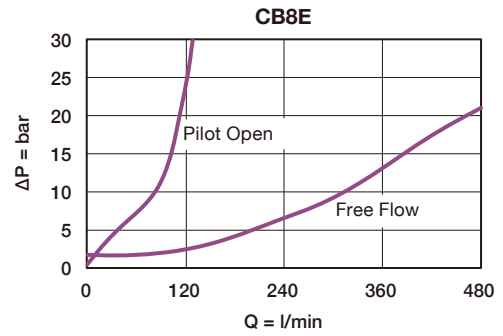
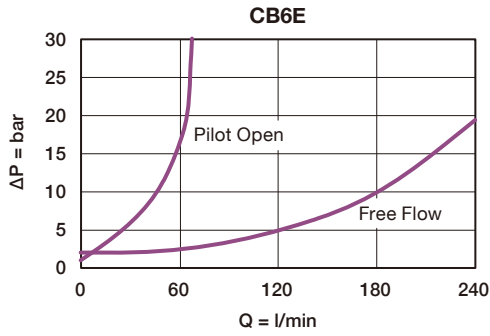
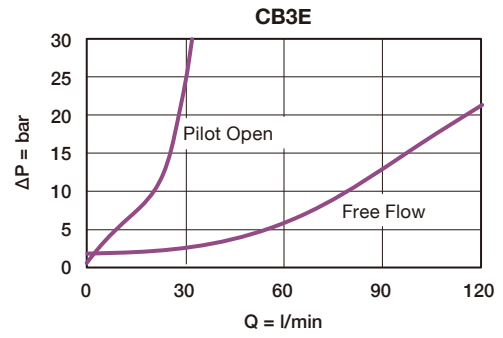
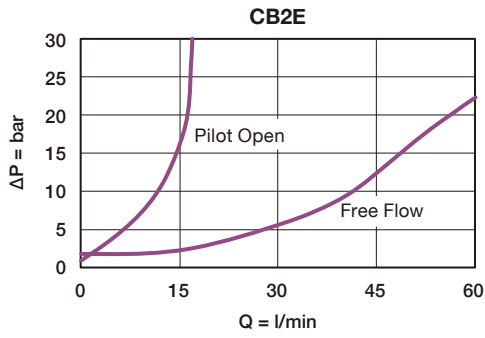

DIMENSION

(UNIT : mm)

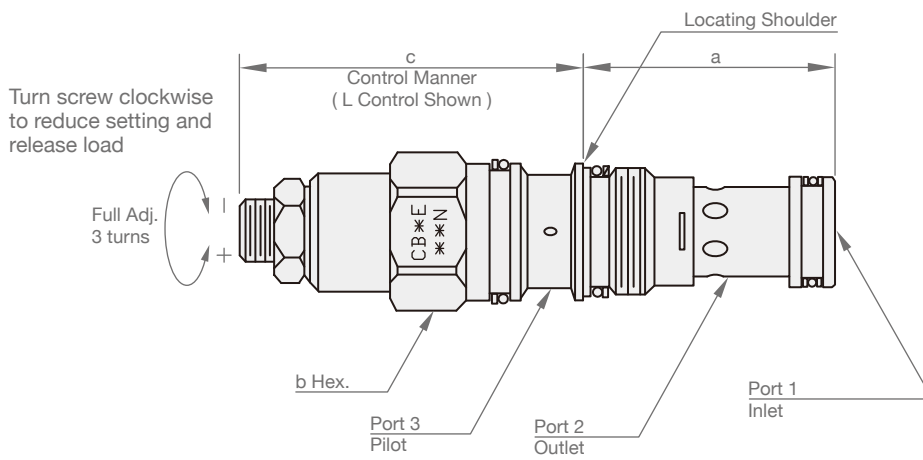

Model	a	b	c
			L
CB2E	34.9	22.2	50
CB3E	34.9	28.6	61
CB6E	46.0	31.8	70
CB8E	63.5	41.3	90

CBF



SYMBOLS

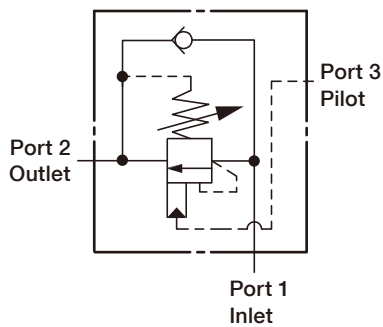

ORDER CODES

CB 2 F - T11A - L K N

1 2 3 4 5 6 7

1	Model Name	CB	
2	Valve Size	2, 3, 6, 8	
3	Pilot Ratio	F	4.5:1
4	Cavity	T11A, T2A, T17A, T19A	
5	Control Manner	L	standard screw adjustment
6	Adjustable Range	J	140 ~ 350 bar, w/1.7 bar check, 210 bar initially setting
		K	70 ~ 175 bar, w/1.7 bar check, 140 bar initially setting
		C	140 ~ 350 bar, w/0.3 bar check, 210 bar initially setting
7	Material of Seal	D	70 ~ 175 bar, w/0.3 bar check, 140 bar initially setting
		N	buna-N
		V	viton

MODEL SPEC.

Model	Cavity	Capacity (l/min)	Max. Pressure (bar)	Installation Torque (Nm)	Operational Temperature	Weight (kg)
CB2F	T11A	15	350	40/50	-35 ~ 100°C (-31 ~ 212°F)	0.17
CB3F	T2A	30	350	60/70		0.30
CB6F	T17A	60	350	200/215		0.64
CB8F	T19A	80	350	465/500		1.47

PERFORMANCE CURVES

Free Flow and Piloted Open Pressure Drop

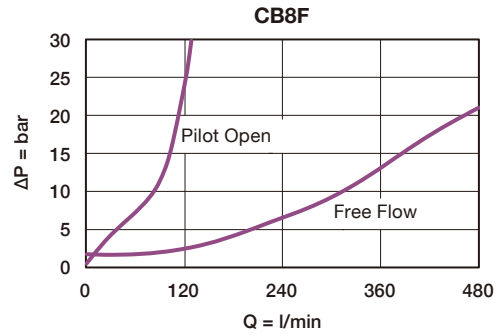
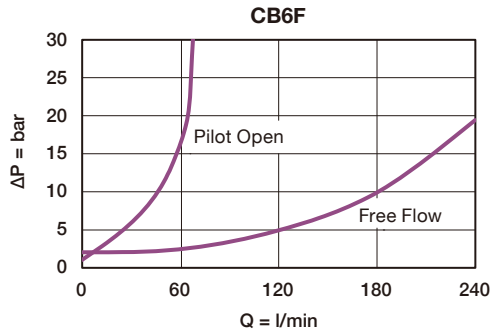
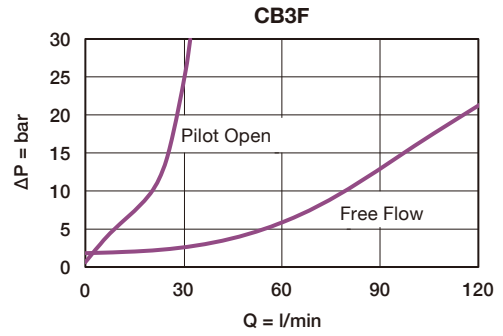
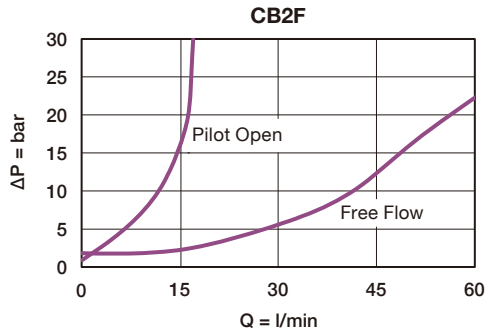

DIMENSION

(UNIT : mm)

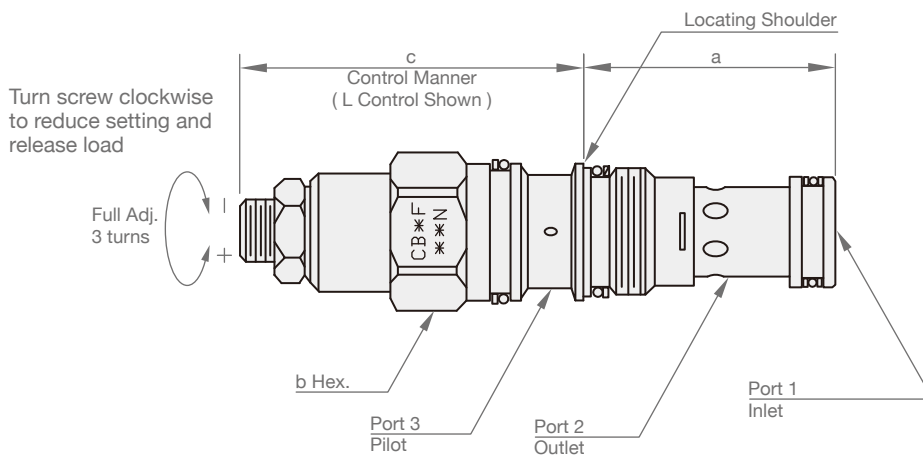

Model	a	b	c
			L
CB2F	34.9	22.2	50
CB3F	34.9	28.6	61
CB6F	46.0	31.8	70
CB8F	63.5	41.3	90

LO



ORDER CODES

LO 2 C - T11A - X D N

1 2 3 4 5 6 7

1	▶ Model Name	LO
2	▶ Valve Size	2, 3, 6, 8
3	▶ Operation	A, B, C, D, O
4	▶ Cavity	T11A, T2A, T17A, T19A
5	▶ Control Manner	X unadjustable L standard screw adjustment

6	▶ Cracking Pressure (bar)	D	Type A, B, C, D, Port1 : 3.5 Type O, Port 3 : 2
7	▶ Material of Seal	N	buna-N
		V	viton

SYMBOLS

LO*A	LO*B	LO*C	LO*D	LO*O
Vent-to-Open	Vent-to-Open	Pilot-to-Close	Vent-to-Open	Pilot-to-Close
Spring biased closed, pilot source from port 1	Spring biased closed, pilot source from port 2	Spring biased closed, pilot source from port 3	Spring biased closed, higher of port 1 or 2 pilot source	Spring biased open, pilot source from port 3

MODEL SPEC.

Model	Cavity	Capacity (l/min)	Max. Pressure (bar)	Installation Torque (Nm)	Control Orifice Diameter (mm)	Operational Temperature	Weight (kg)
LO2*	T11A	80	350	40/50	Ø0.5	-35 ~ 100°C (-31 ~ 212°F)	0.12
LO3*	T2A	160	350	60/70	Ø0.5		0.22
LO6*	T17A	320	350	200/215	Ø0.8		0.50
LO8*	T19A	640	350	465/500	Ø0.9		1.15

Area ratio, A3 to A1 : 1.8:1 (with sealed piston)

Area ratio, A3 to A2 : 2.25:1 (with sealed piston)

PERFORMANCE CURVES

► Typical Pressure Drop

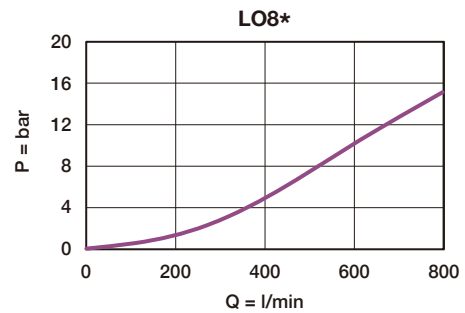
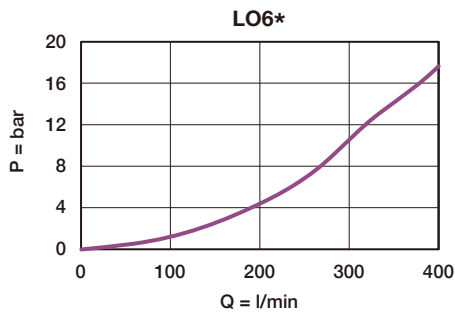
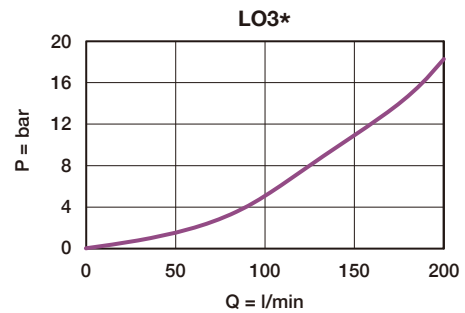
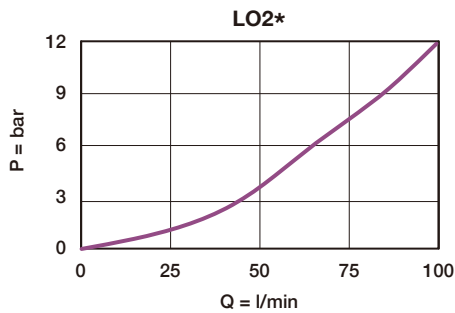

DIMENSION

(UNIT : mm)

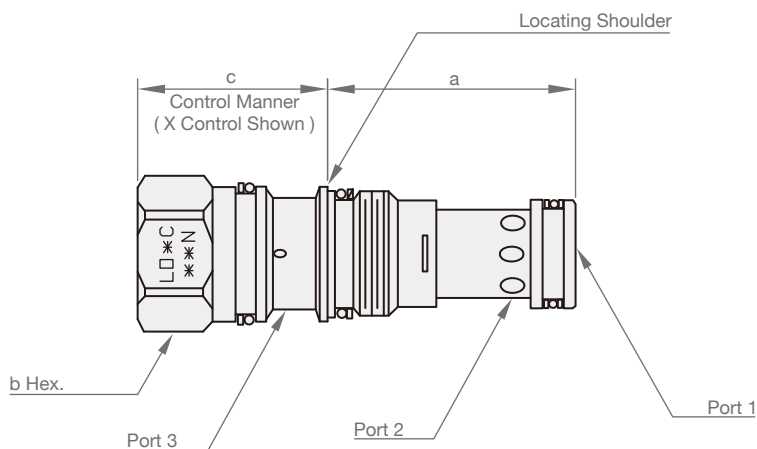

Model	a	b	c	
			X	L
LO2*	34.9	22.2	31	64
LO3*	34.9	28.6	35	72
LO6*	46.0	31.8	46	84
LO8*	63.5	41.3	59	100

QC



SYMBOLS

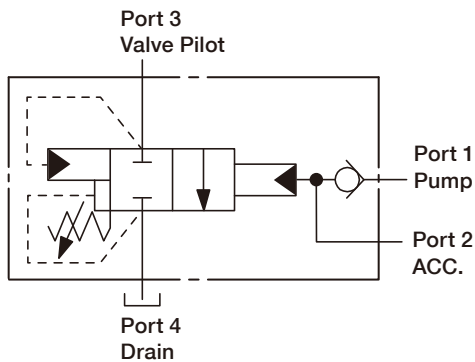

ORDER CODES

QC **2** **C** - **T21A** - **L** **A** **N**

1 2 3 4 5 6 7

1	▶ Model Name	QC
2	▶ Valve Size	2
3	▶ Operation	C 30% ratio between unload setting and reset
4	▶ Cavity	T21A
5	▶ Control Manner	L standard screw adjustment
		K hand knob with lock knob
6	▶ Adjustable Range	A 70 ~ 210 bar, 70 bar standard setting
		B 35 ~ 105 bar, 35 bar standard setting
		C 140 ~ 350 bar, 140 bar standard setting
		D 18 ~ 55 bar, 18 bar standard setting
7	▶ Material of Seal	N buna-N
		V viton

MODEL SPEC.

Model	Cavity	Capacity (l/min)	Max. Pressure (bar)	Installation Torque (Nm)	Operational Temperature	Weight (kg)
QC2C	T21A	60	350	41/47	-35 ~ 100°C (-31 ~ 212°F)	0.19

PERFORMANCE CURVES

► Pressure Differential vs. Flow

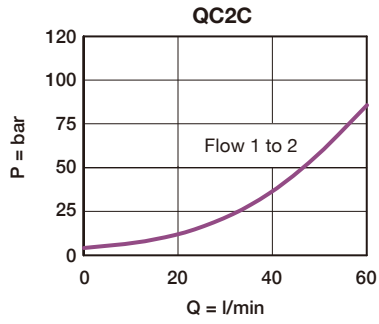

► Pressure Differential vs. Flow (Full Piloted Open)

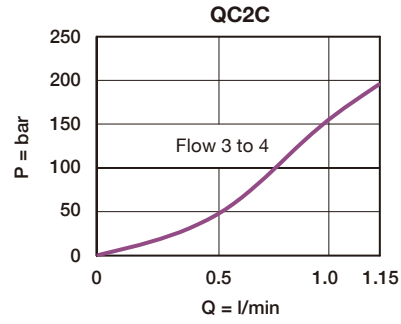

DIMENSION

(UNIT : mm)

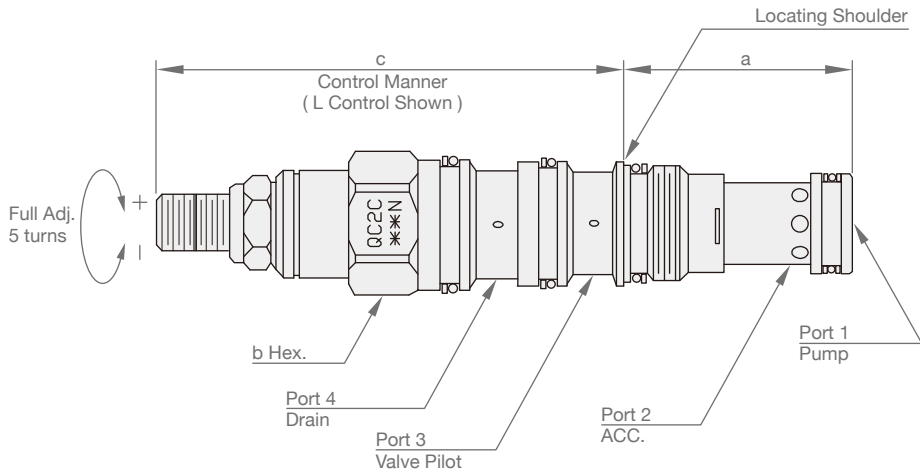

Model	a	b	c	
			L	K
QC2C	34.9	22.2	78.5	84.8

OA2

SYMBOLS

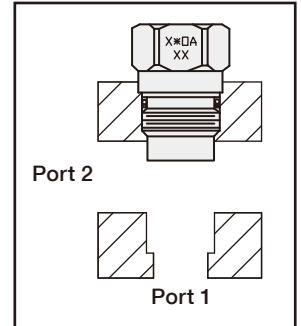
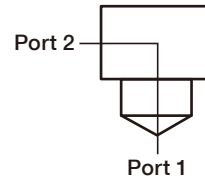

MODEL SPEC.

Model	Cavity	Thread	Material of Seal	Weight (kg)
X10A2-T162A-XX	T162A	M16 P15	buna-N	0.05
X20A2-T10A-XX	T10A	M20 P1.5		0.09
X20A2-T13A-XX	T13A	M20 P1.5		0.09
X30A2-T3A-XX	T3A	1"-14UNS-2B		0.13
X30A2-T5A-XX	T5A	1"-14UNS-2B		0.13
X60A2-T16A-XX	T16A	M36 P2		0.28
X80A2-T18A-XX	T18A	M48 P2		0.57

DIMENSION

(UNIT : mm)

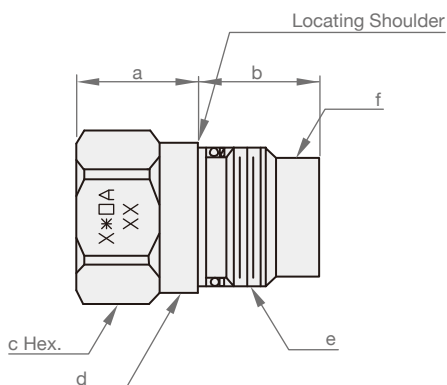

Model	a	b	c	d	e	f
X20A2	20.3	16.3	22.2	Ø21.7	M16 P1.5-6H	Ø17.4
X30A2	17.8	22.2	28.6	Ø27.3	1"-14UNS-2B	Ø22.6
X60A2	26	25	31.7	Ø39.7	M36 P2.0-6H	Ø33
X80A2	30.4	26.8	41.2	Ø52.5	M48 P2.0-6H	Ø43

CA2

SYMBOLS

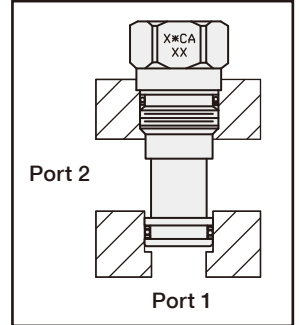
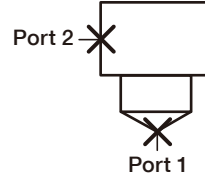

MODEL SPEC.

Model	Cavity	Thread	Material of Seal	Weight (kg)
X1CA2-T162A-XX	T162A	M16 P15	buna-N	0.07
X2CA2-T10A-XX	T10A	M20 P1.5		0.12
X2CA2-T13A-XX	T13A	M20 P1.5		0.12
X3CA2-T3A-XX	T3A	1"-14UNS-2B		0.21
X3CA2-T5A-XX	T5A	1"-14UNS-2B		0.20
X6CA2-T16A-XX	T16A	M36 P2		0.49
X8CA2-T18A-XX	T18A	M48 P2		1.10

DIMENSION

(UNIT : mm)

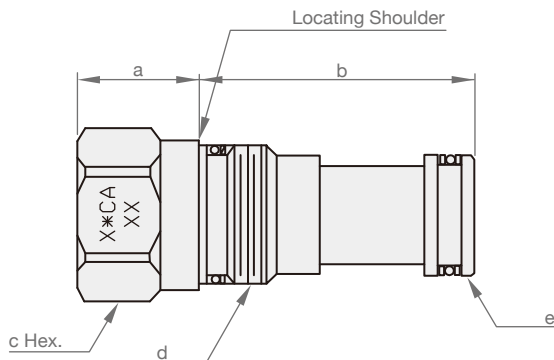

Model	a	b	c	d	e
X2CA2	20.2	38.2	22.2	M16 P1.5-6H	Ø17.4
X3CA2	17.8	47.7	28.6	1"-14UNS-2B	Ø22.2
X6CA2	25.7	60.8	31.7	M32 P2.0-6H	Ø31.7
X8CA2	30	79.6	41.2	M48 P2.0-6H	Ø41.2

OA3

SYMBOLS

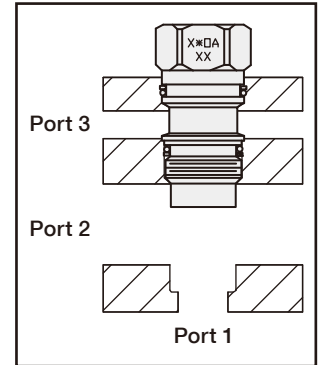
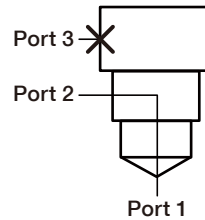

MODEL SPEC.

Model	Cavity	Thread	Material of Seal	Weight (kg)
X10A3-T163A-XX	T163A	M16 P1.5	buna-N	0.06
X20A3-T11A-XX	T11A	M20 P1.5		0.09
X30A3-T2A-XX	T2A	1"-14UNS-2B		0.16
X60A3-T17A-XX	T17A	M36 P2		0.31
X80A3-T19A-XX	T19A	M48 P2		0.68

DIMENSION

(UNIT : mm)

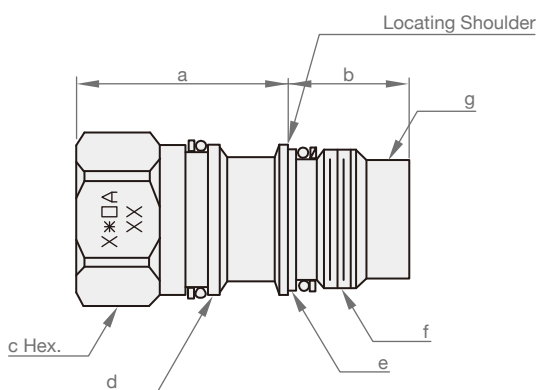

Model	a	b	c	d	e	f	g
X10A3	31.86	14.54	19.1	Ø17.8	Ø16.6	M16 P1.5-6H	Ø13.9
X20A3	30	17.8	22.2	Ø21.7	Ø20.5	M16 P1.5-6H	Ø17.4
X30A3	35.2	15.2	28.6	Ø27.3	Ø26	1"-14UNS-2B	Ø22.8
X60A3	46.2	18.3	31.6	Ø39.6	Ø36.4	M36 P2.0-6H	Ø32.5
X80A3	59	23.5	41	Ø52.4	Ø48.2	M36 P2.0-6H	Ø43

CA3

SYMBOLS

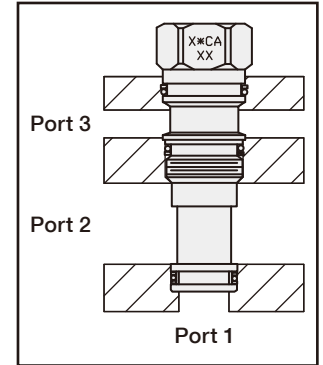
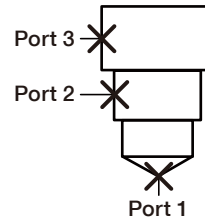

MODEL SPEC.

Model	Cavity	Thread	Material of Seal	Weight (kg)
X1CA3-T163A-XX	T163A	M16 P1.5	buna-N	0.08
X2CA3-T11A-XX	T11A	M20 P1.5		0.12
X3CA3-T2A-XX	T2A	1"-14UNS-2B		0.22
X6CA3-T17A-XX	T17A	M36 P2		0.52
X8CA3-T19A-XX	T19A	M48 P2		1.20

DIMENSION

(UNIT : mm)

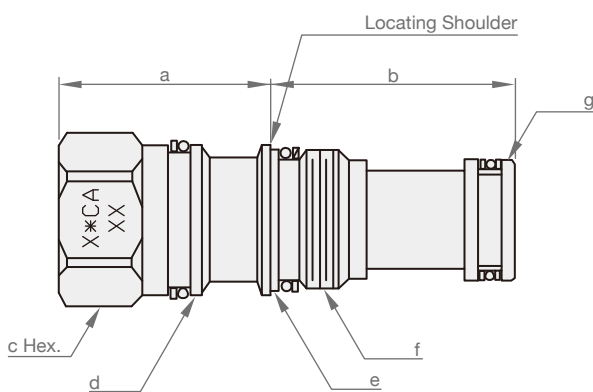

Model	a	b	c	d	e	f	g
X1CA3	32	31	19.1	Ø17.8	Ø16.6	M16 P1.5-6H	Ø13.9
X2CA3	30.5	34.8	22.2	Ø21.8	Ø20.5	M16 P1.5-6H	Ø17.3
X3CA3	35	35	28.6	Ø27.3	Ø26	1"-14UNS-2B	Ø22.1
X6CA3	46.4	46	31.6	Ø39.6	Ø36.4	M36 P2.0-6H	Ø31.6
X8CA3	46.4	46	31.6	Ø39.6	Ø36.4	M36 P2.0-6H	Ø31.6

MH



SYMBOLS

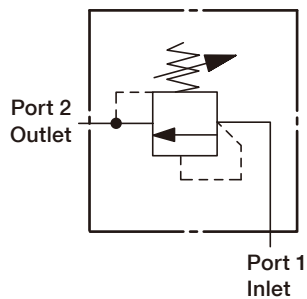

ORDER CODES

MH - **082** - **L** **A** **N**

1 2 3 4 5

1	▶ Model Name	MH	
2	▶ Valve Size & Cavity	082, 092, 102	
3	▶ Control Manner	L	standard screw adjustment
		K	hand knob with lock knob
		C	tamper resistant cover
4	▶ Adjustable Range	A	7 ~ 210 bar
		B	3.5 ~105 bar
		C	90 ~ 350 bar
5	▶ Material of Seal	N	buna-N
		V	viton

MODEL SPEC.

Model	Cavity	Capacity (l/min)	Max. Pressure (bar)	Installation Torque (Nm)	Operational Temperature	Weight (kg)
MH-082	T082	25	350	40/50	-35 ~ 100°C (-31 ~ 212°F)	0.15
MH-092	T092	45	350	40/50		0.25
MH-102	T102	55	350	40/50		0.20

PERFORMANCE CURVES

► Typical Pressure Rise

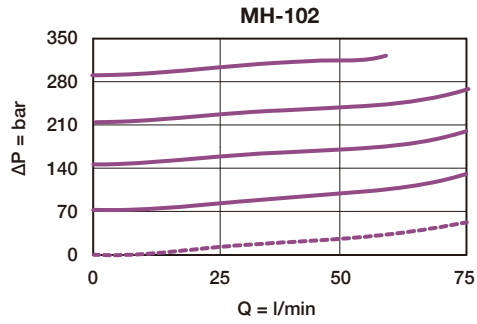
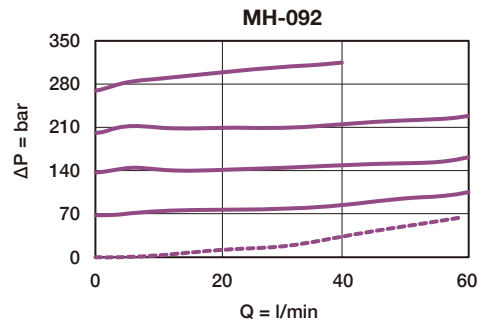
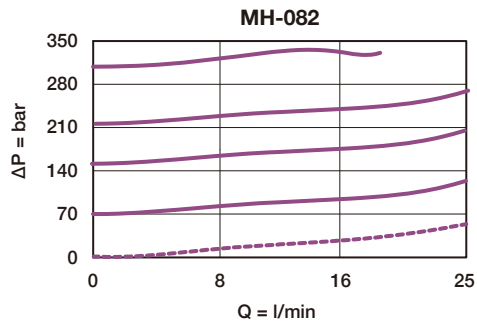

DIMENSION

(UNIT : mm)

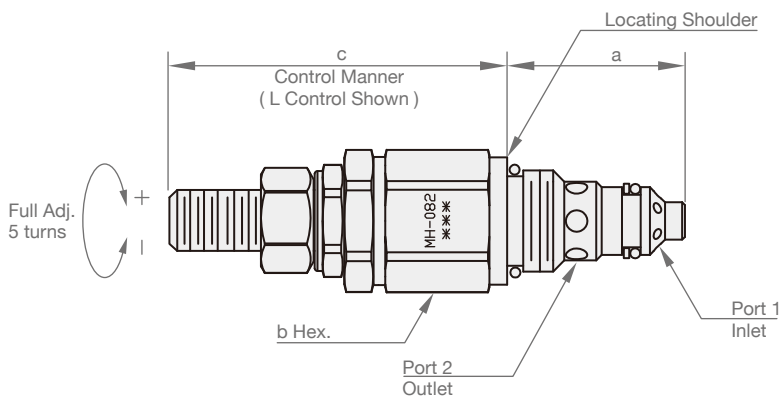

Model	a	b	c	
			L	K
MH-082	34	24	60	66
MH-092	54	26	58	93
MH-102	38.8	25.4	58	64

CN



SYMBOLS

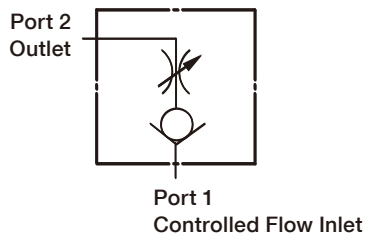

ORDER CODES

CN - **082** - **L** **A** **N**

1 2 3 4 5

1	▶ Model Name	CN	
2	▶ Cavity & Max. Orifice	082, 102, 122, 162	
3	▶ Control Manner	L	standard screw adjustment
		K	hand knob with lock knob
4	▶ Cracking Pressure	A	0.3 bar
		C	2.0 bar
		E	5.0 bar
5	▶ Material of Seal	N	buna-N
		V	viton

MODEL SPEC.

Model	Cavity	Capacity (l/min)	Max. Pressure (bar)	Installation Torque (Nm)	Operational Temperature	Weight (kg)
CN-082	T082	30	300	40/50	-35 ~ 100°C (-31 ~ 212°F)	0.11
CN-102	T102	50	300	40/50		0.14
CN-122	T122	80	300	40/50		0.26
CN-162	T162	150	300	40/50		0.39

PERFORMANCE CURVES

► Typical Pressure Drop

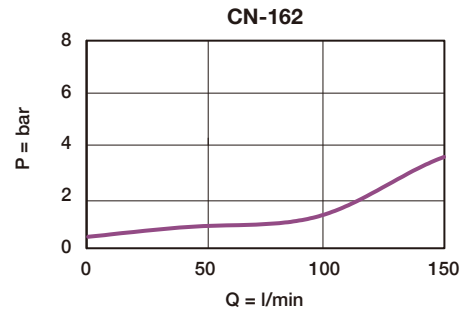
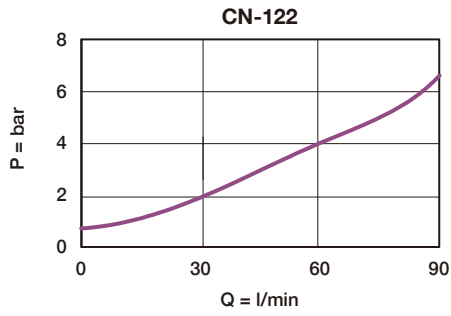
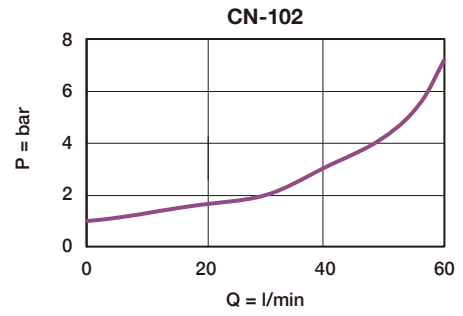
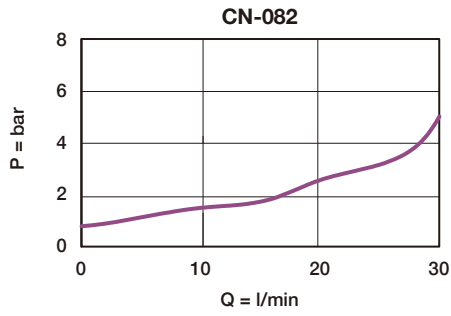

DIMENSION

(UNIT : mm)

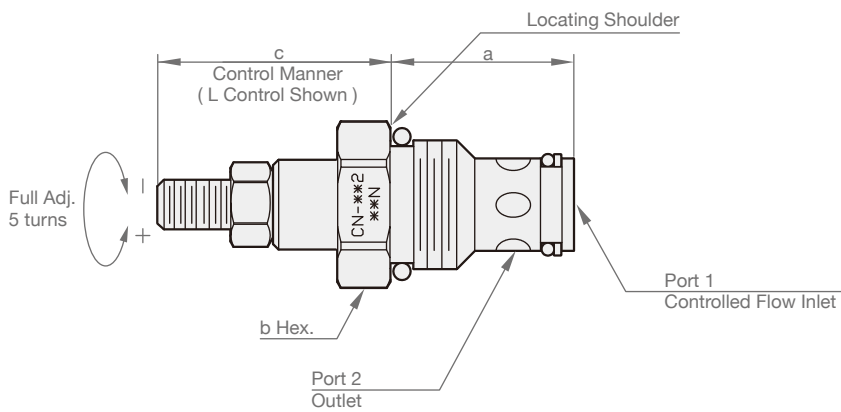

Model	a	b	c	
			L	K
CN-082	27.7	22.4	48	53
CN-102	31.8	25.4	51	56
CN-122	46.0	31.8	53	58
CN-162	44.5	38.1	59	64

NV



SYMBOLS

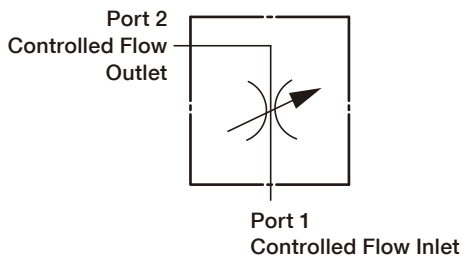

ORDER CODES

NV - **082** - **L** **A** **N**

1 2 3 4

1	▶ Model Name	NV	
2	▶ Cavity & Max. Orifice	082	T082, 6.5mm
		102	T102, 8.5mm
		122	T122, 12.5mm
		162	T162, 16mm
3	▶ Control Manner	L	standard screw adjustment
		K	hand knob with lock knob
4	▶ Material of Seal	N	buna-N
		V	viton

MODEL SPEC.

Model	Cavity	Capacity (l/min)	Max. Pressure (bar)	Installation Torque (Nm)	Operational Temperature	Weight (kg)
NV-082	T082	30	300	40/50	-35 ~ 100°C (-31 ~ 212°F)	0.11
NV-102	T102	50	300	40/50		0.14
NV-122	T122	80	300	40/50		0.26
NV-162	T162	150	300	40/50		0.39

PERFORMANCE CURVES

Typical Pressure Drop

— Fully Open, Port1 ~ Port2

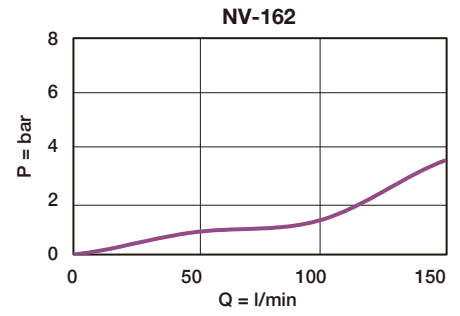
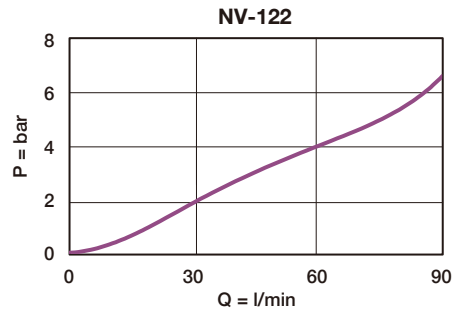
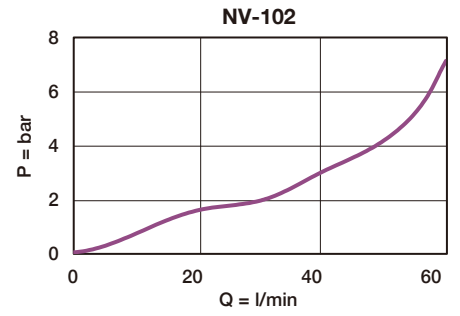
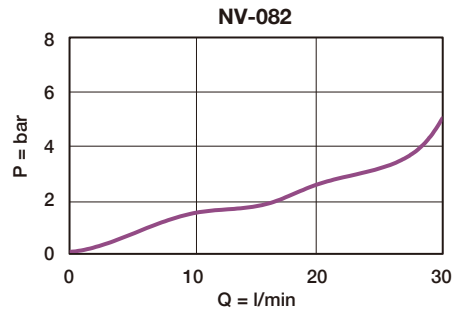

DIMENSION

(UNIT : mm)

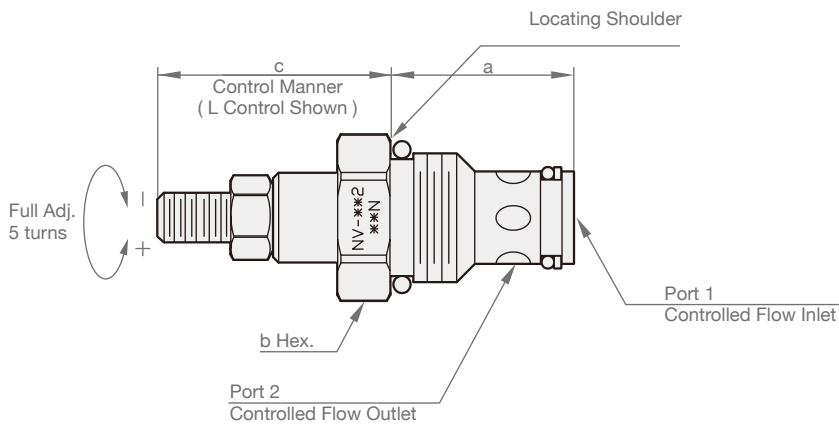

Model	a	b	c	
			L	K
NC-082	27.7	22.4	48	53
NC-102	31.8	25.4	51	56
NC-122	46.0	31.8	53	58
NC-162	44.5	38.1	59	64

NC



SYMBOLS

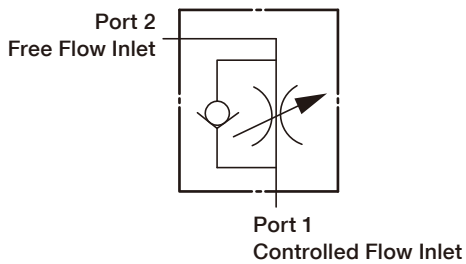

ORDER CODES

NC - **082** - **L** **A** **N**

1 2 3 4

1 ▶	Model Name	NC	
2 ▶	Cavity & Max. Orifice	082	T082, 5.9mm
		102	T102, 8mm
		122	T122, 11mm
		162	T162, 13mm
3 ▶	Control Manner	L	standard screw adjustment
		K	hand knob with lock knob
4 ▶	Material of Seal	N	buna-N
		V	viton

MODEL SPEC.

Model	Cavity	Capacity (l/min)	Max. Pressure (bar)	Installation Torque (Nm)	Operational Temperature	Weight (kg)
NC-082	T082	30	300	40/50	-35 ~ 100°C (-31 ~ 212°F)	0.11
NC-102	T102	50	300	40/50		0.14
NC-122	T122	80	300	40/50		0.26
NC-162	T162	150	300	40/50		0.39

PERFORMANCE CURVES

Typical Pressure Drop

- Free Flow, Port1 ~ Port2
- Fully Open, Port2 ~ Port1

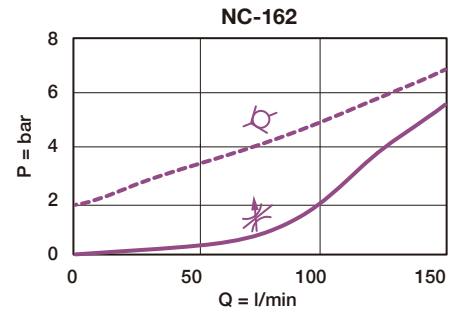
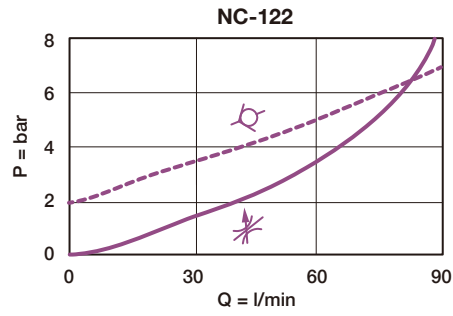
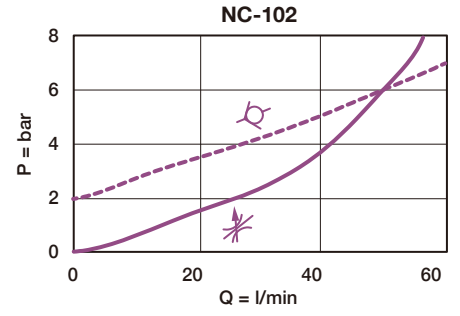
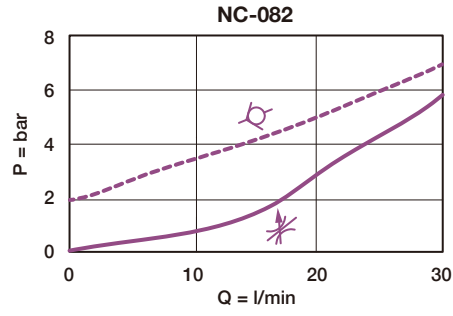

DIMENSION

(UNIT : mm)

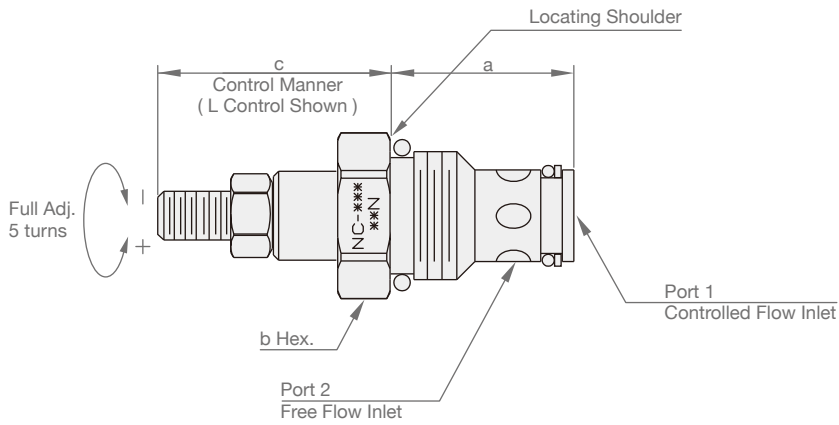

Model	a	b	c	
			L	K
NC-082	27.7	22.4	48	53
NC-102	31.8	25.4	51	56
NC-122	46.0	31.8	53	58
NC-162	44.5	38.1	59	64

CP



SYMBOLS

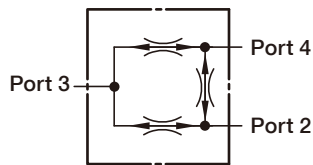

Flow Ratio:
Port 2 : Port 4 = 1:1

ORDER CODES

CP - **104** - **X** **C** **N**

① ② ③ ④ ⑤

①	▶ Model Name	CP
②	▶ Valve Size & Cavity	104, 124, 164
③	▶ Control Manner	X unadjustable
④	▶ Capacity (l/min)	A CP-104: 7.6, CP-124: 38, CP-164: 91
		B CP-104: 23, CP-124: 53, CP-164: 114
		C CP-104: 45, CP-124: 90, CP-164: 150
⑤	▶ Material of Seal	N buna-N
		V viton

MODEL SPEC.

Model	Cavity	Capacity (l/min)	Max. Pressure (bar)	Installation Torque (Nm)	Operational Temperature	Weight (kg)
CP-104	T104	45	210	35/45	-35 ~ 100°C (-31 ~ 212°F)	0.11
CP-124	T124	90	210	45/55		0.23
CP-164	T164	150	210	60/70		0.37

PERFORMANCE CURVES

► Typical Pressure Drop

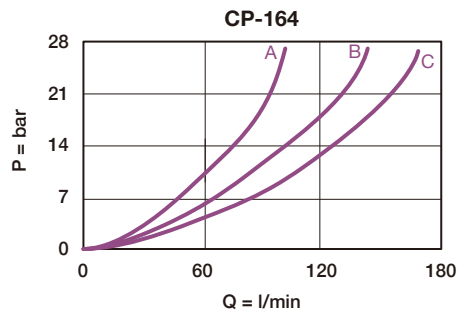
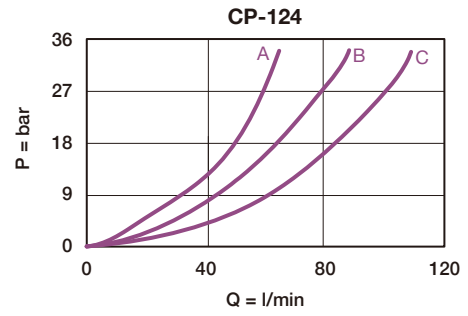
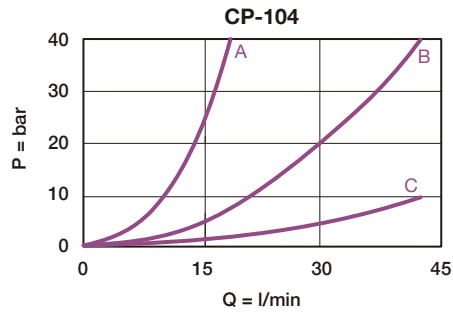

DIMENSION

(UNIT : mm)

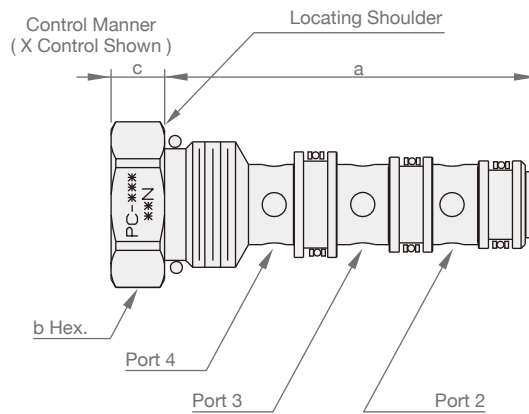

Model	a	b	c
			X
CP-104	64.8	25.4	7.9
CP-124	85.1	31.8	9.5
CP-164	105.0	38.1	12.7

CV



SYMBOLS

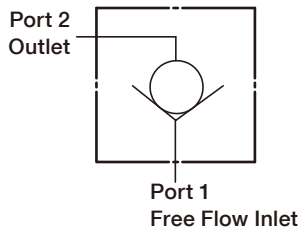

ORDER CODES

CV - **082** - **X** **A** **N**

1 2 3 4 5

1	▶ Model Name	CV	
2	▶ Valve Size & Cavity	082, 102, 122, 162	
3	▶ Control Manner	X	unadjustable
4	▶ Cracking Pressure	A	0.3 bar
		C	2.0 bar
		E	5.0 bar
5	▶ Material of Seal	N	buna-N
		V	viton

MODEL SPEC.

Model	Cavity	Capacity (l/min)	Max. Pressure (bar)	Installation Torque (Nm)	Operational Temperature	Weight (kg)
CV-082	T082	30	300	40/50	-35 ~ 100°C (-31 ~ 212°F)	0.06
CV-102	T102	50	300	40/50		0.09
CV-122	T122	80	300	40/50		0.15
CV-162	T162	150	300	40/50		0.27

PERFORMANCE CURVES

► Typical Pressure Drop

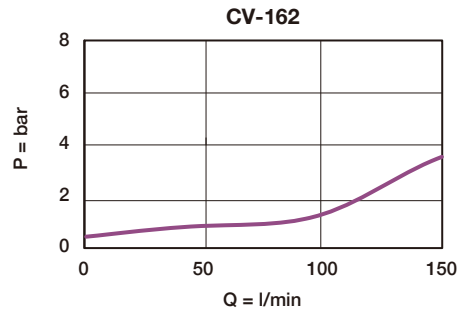
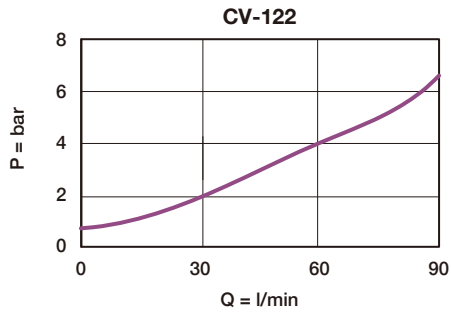
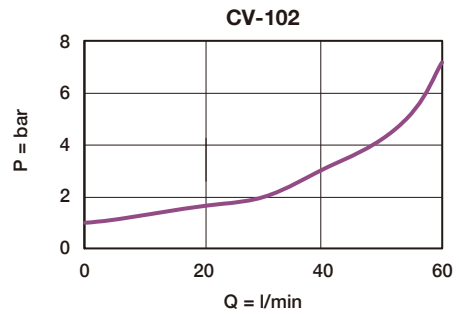
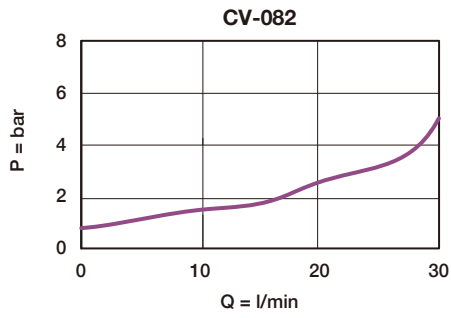

DIMENSION

(UNIT : mm)

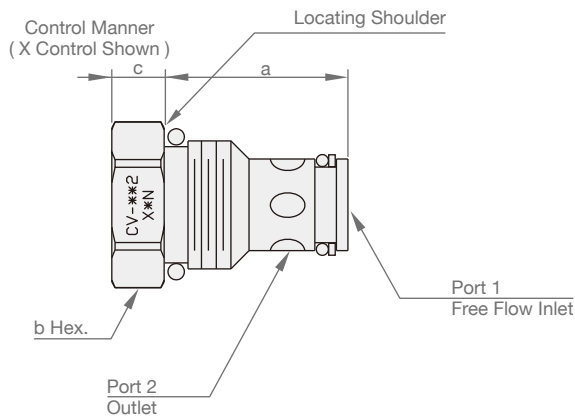

Model	a	b	c
			X
CV-082	27.7	22.4	7.9
CV-102	31.8	25.4	7.9
CV-122	46.0	31.8	9.5
CV-162	44.5	38.1	14.0

LS



SYMBOLS

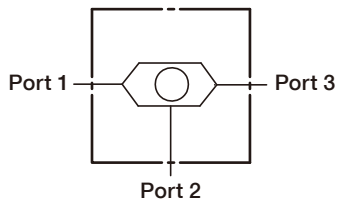

ORDER CODES

LS - **083** - **X** X **N**

① ② ③ ④

① ▶	Model Name	LS	
② ▶	Valve Size & Cavity	083, 103	
③ ▶	Control Manner	X	unadjustable
④ ▶	Material of Seal	N	buna-N
		V	viton

MODEL SPEC.

Model	Cavity	Capacity (l/min)	Max. Pressure (bar)	Installation Torque (Nm)	Operational Temperature	Weight (kg)
LS-083	T083	15	240	30/40	-35 ~ 100°C (-31 ~ 212°F)	0.06
LS-103	T103	30	240	40/50		0.10

PERFORMANCE CURVES

► Typical Pressure Drop

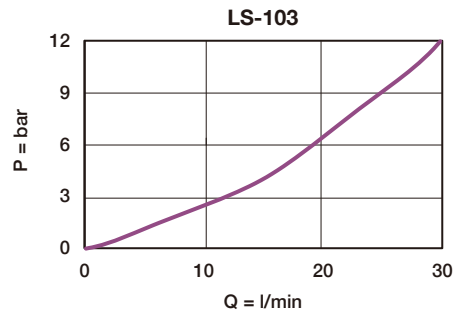
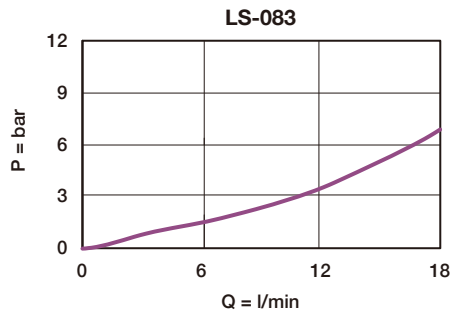

DIMENSION

(UNIT : mm)

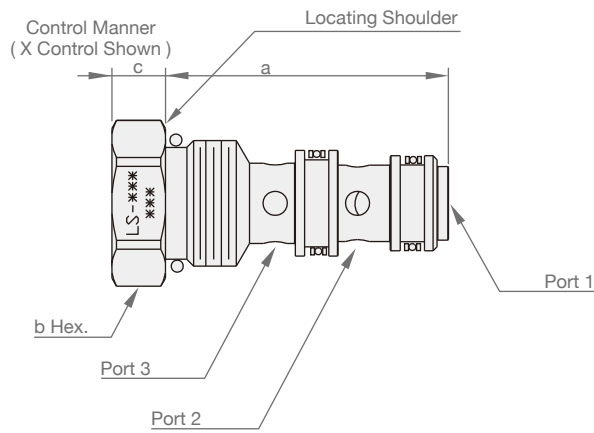

Model	a	b	c
			X
LS-083	42.2	22.4	8
LS-103	46.0	25.4	8

HS, JS, LS, PS-2



SYMBOLS

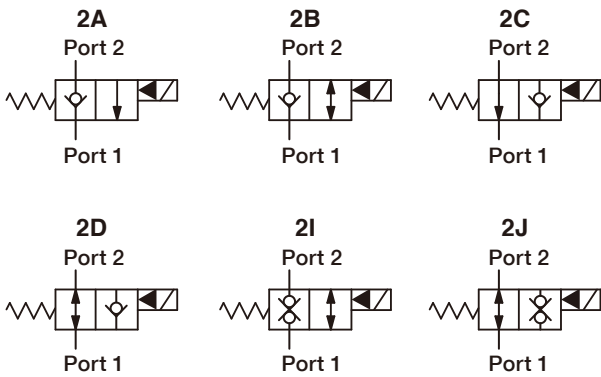

ORDER CODES

LS - **2A** - **16** - **A1**

1 2 3 4

1 ▶ Cavity	HS	T082
	JS	T102
	LS	T122
	PS	T162
2 ▶ Type of Valve	2A, 2B, 2C, 2D, 2I, 2J (Please refer to the symbol list.)	
	16, 19	
3 ▶ Tube Diameter	16, 19	
4 ▶ Power Source	A1	RAC110V
	A2	RAC220V
	D1	DC12V
	D2	DC24V

MODEL SPEC.

Model	Cavity	Capacity (l/min)	Max. Pressure (bar)	Installation Torque (Nm)	Weight (kg)
HS-2A-16	T082	28	250	39/51	0.41
HS-2B-16	T082	28	250	39/51	0.41
HS-2C-16	T082	28	250	39/51	0.41
HS-2D-16	T082	30	250	39/51	0.41
HS-2J-16	T082	12	250	39/51	0.41
JS-2A-16	T102	50	250	39/51	0.43
JS-2B-16	T102	50	250	39/51	0.43
JS-2C-16	T102	50	250	39/51	0.43
JS-2D-16	T102	55	250	39/51	0.46
JS-2I-16	T102	20	250	39/51	0.45
HS-2J-16	T082	12	250	39/51	0.41

MODEL SPEC.

Model	Cavity	Capacity (l/min)	Max. Pressure (bar)	Installation Torque (Nm)	Weight (kg)
LS-2A-16	T122	100	250	39/51	0.53
LS-2B-16	T122	100	250	39/51	0.53
LS-2C-16	T122	100	250	39/51	0.56
LS-2D-16	T122	105	250	39/51	0.56
LS-2I-16	T122	40	250	39/51	0.56
PS-2A-19	T162	150	250	39/51	0.62
PS-2B-19	T162	150	250	39/51	0.62
PS-2C-19	T162	150	250	39/51	0.67
PS-2D-19	T162	150	250	39/51	0.67
PS-2I-19	T162	60	250	39/51	0.67

DIMENSION

(UNIT : mm)

▶ HS-2*

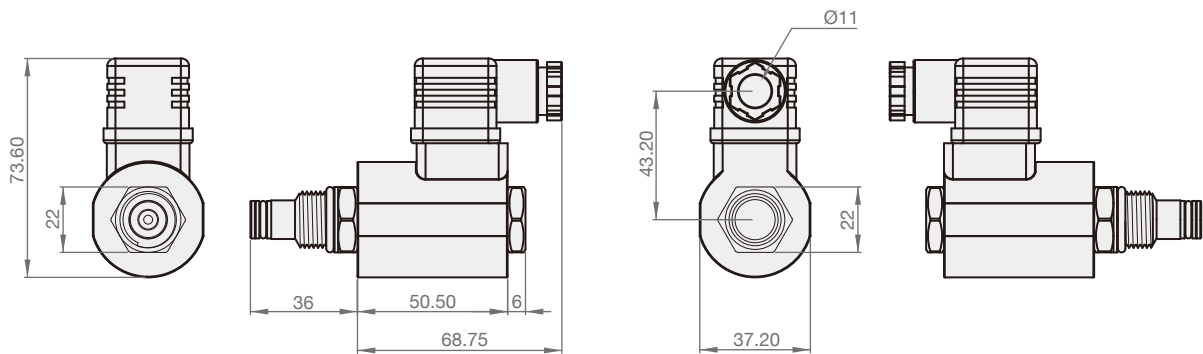

▶ JS-2*

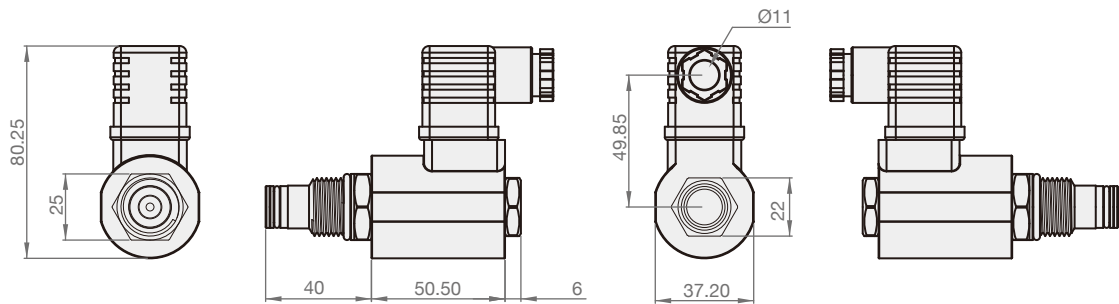

▶ LS-2*

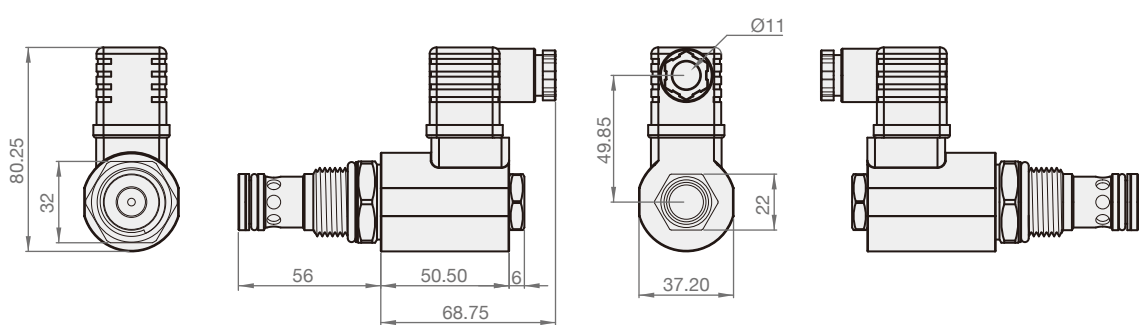

▶ PS-2*

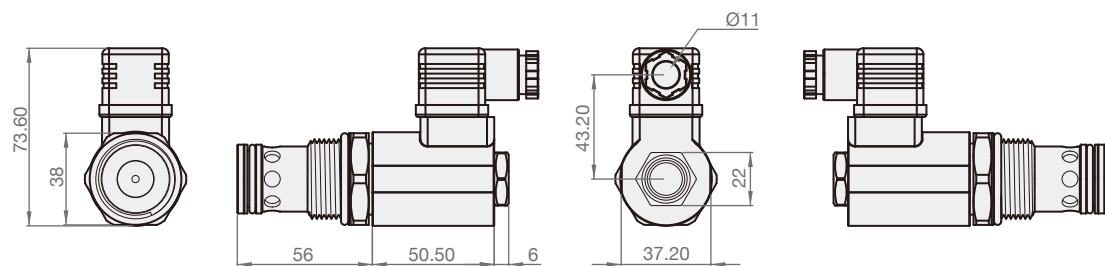

HS-3



SYMBOLS

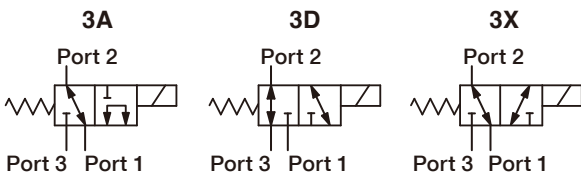

ORDER CODES

HS - **3A** - **16** - **D2**

1 2 3 4

1	Cavity	HS	T082
2	Type of Valve	3A, 3D, 3X (Please refer to the symbol list.)	
3	Tube Diameter	16	
4	Power Source	A1	RAC110V
		A2	RAC220V
		D1	DC12V
		D2	DC24V

MODEL SPEC.

Model	Cavity	Capacity (l/min)	Max. Pressure (bar)	Installation Torque (Nm)	Weight (kg)
HS-3A-16	T082	15	250	39/51	0.43
HS-3D-16	T082	11	250	39/51	0.43
HS-3X-16	T082	13	250	39/51	0.43

► HS-3*

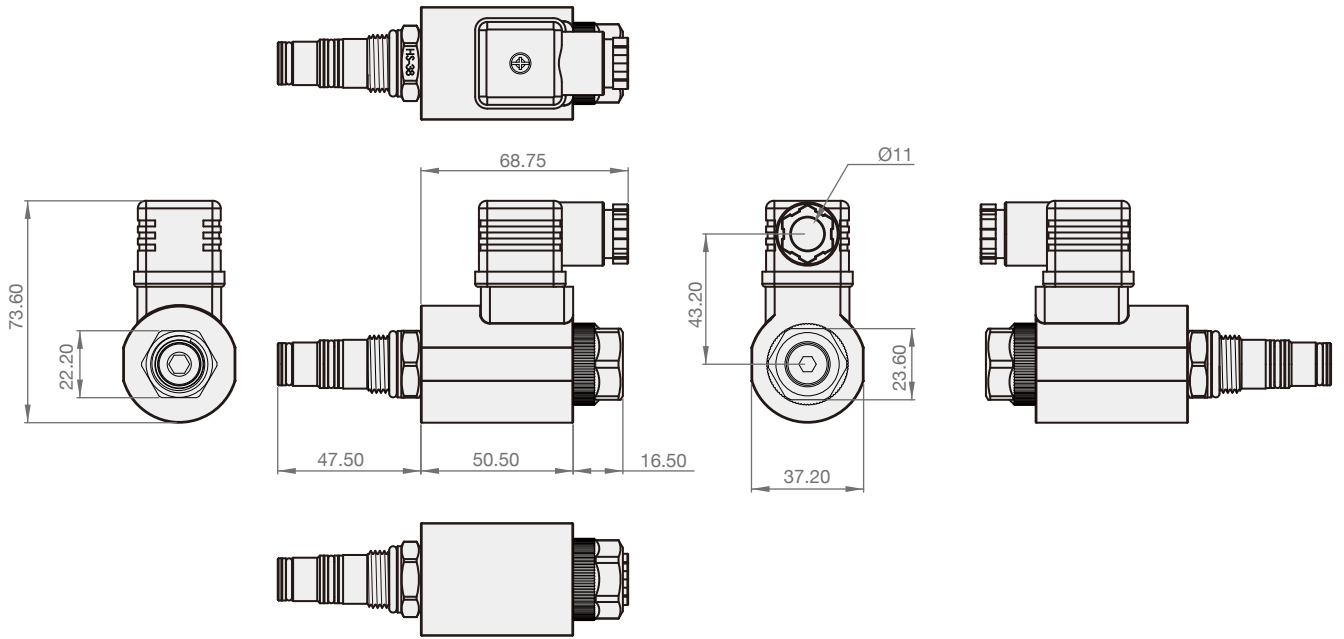

PV-1033



SYMBOLS

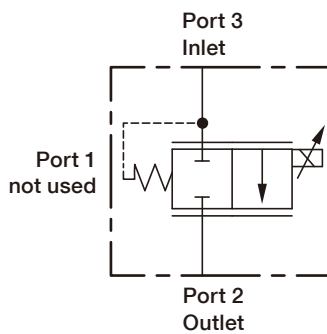

ORDER CODES

PV - 103 3 - X B N - D 24

1 2 3 4 5 6 7 8

1	▶ Model Name	PV
2	▶ Cavity	103
3	▶ Type	3 normally closed
4	▶ Control Manner	X unadjustable
5	▶ Capacity	B 30 l/min
6	▶ Material of Seal	N buna-N V viton
7	▶ Connector (coil)	D ISO/DIN43650
8	▶ Voltage (coil)	12 12 VDC 24 24 VDC

MODEL SPEC.

Model	Cavity	Capacity (l/min)	Max. Pressure (bar)	Leakage (cc/min)	Installation Torque (Nm)
PV-1033	T103	30	300	less than 150	35/38
Model	Hysteresis	Max. Current (mA)		Weight (kg)	
		12 VDC	24 VDC	Body	Coil
PV-1033	5%	1800	900	0.28	0.4

PERFORMANCE CURVES

► Flow vs. Current

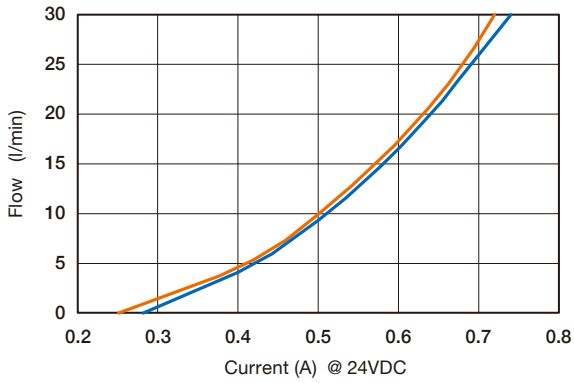

► Pressure Drop vs. Flow

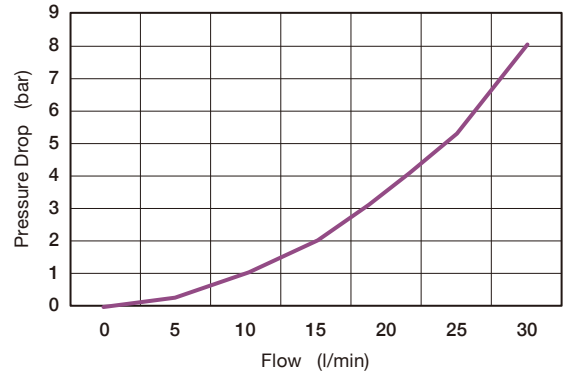

DIMENSION

(UNIT : mm)

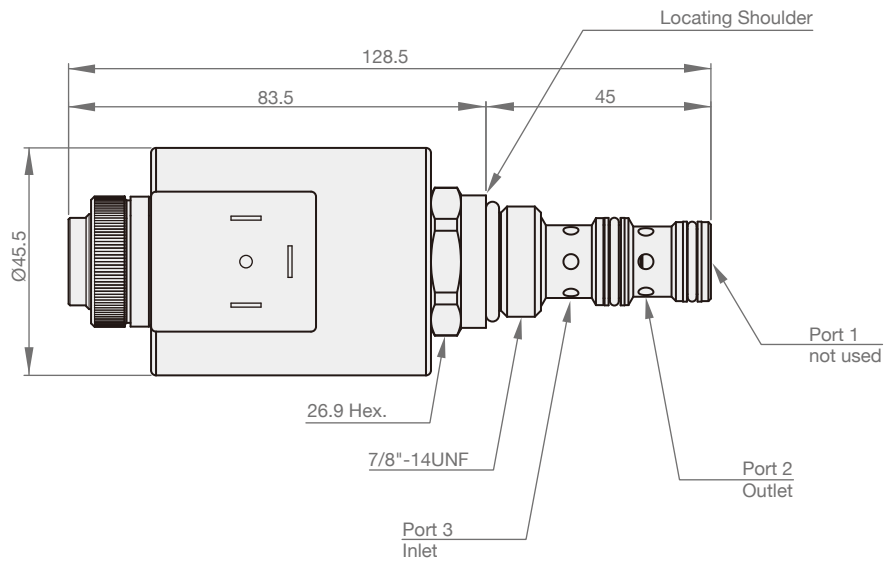

CAVITY TOOLING

(UNIT : mm)

► T103

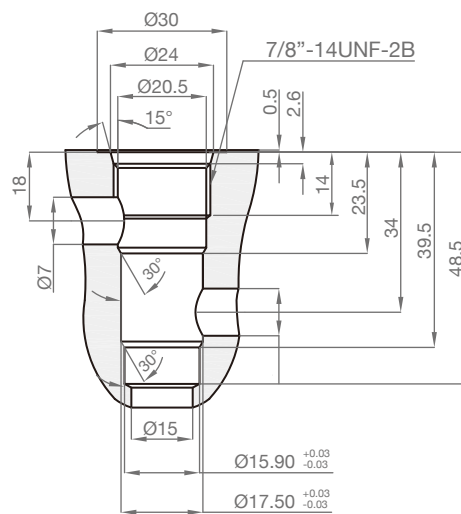

EVP-M33



SYMBOLS

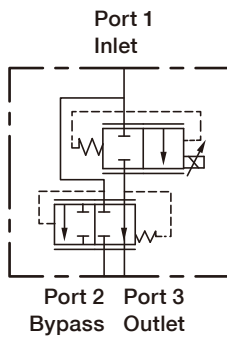

ORDER CODES

EVP - **M33** - **X** **C** **N** - **D** **24**

1 2 3 4 5 6 7

1	Model Name	EVP	
2	Cavity	M33	C332-3
3	Control Manner	X	unadjustable
4	Capacity	C	50 l/min
5	Material of Seal	N	buna-N
		V	viton
6	Connector (coil)	D	ISO/DIN43650
7	Voltage (coil)	12	12 VDC
		24	24 VDC

MODEL SPEC.

Model	Cavity	Capacity (l/min)	Max. Pressure (bar)	Leakage (cc/min)	Installation Torque (Nm)
EVP-M33	C332-3	50	270	less than 150	30/35
Model	Hysteresis	Max. Current (mA)		Weight (kg)	
		12 VDC	24 VDC	Body	Coil
EVP-M33	5%	1900	950	0.5	0.4

PERFORMANCE CURVES

► Flow vs. Current

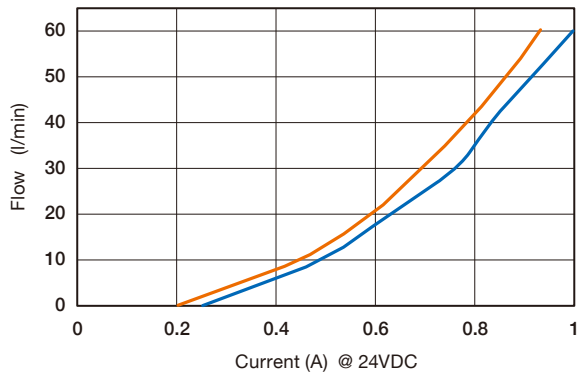

DIMENSION

(UNIT : mm)

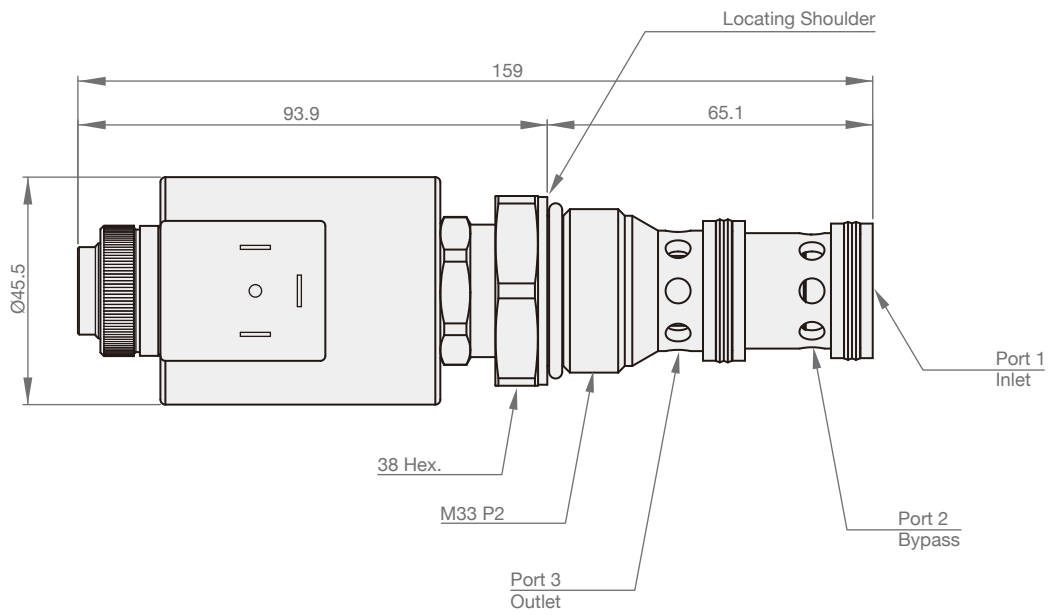

CAVITY TOOLING

(UNIT : mm)

► C332-3

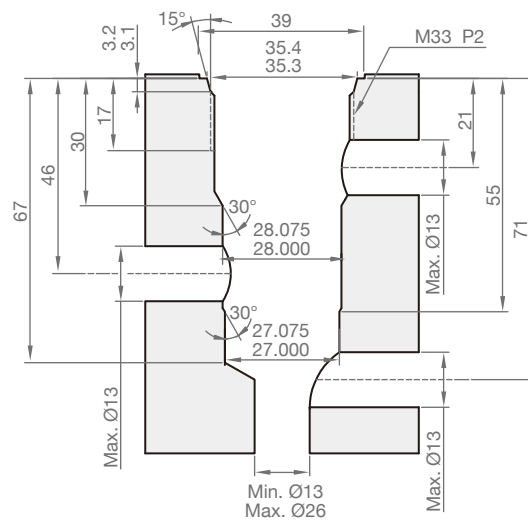

Cavities Tooling

2 Port Cavities Tooling

(UNIT : mm)

► T8A

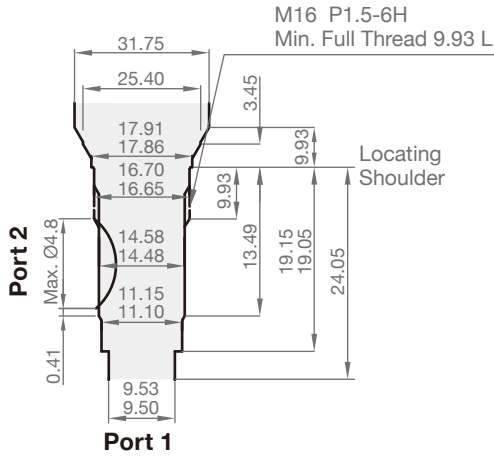

Size	Cavity
01	T8A
02	T10A, T13A
03	T3A, T5A
06	T16A
08	T18A

► T10A

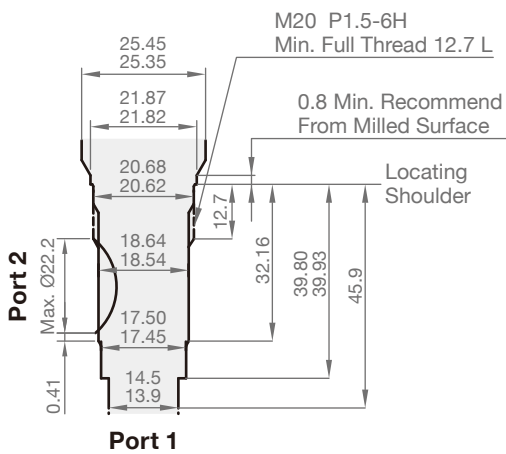

► T13A

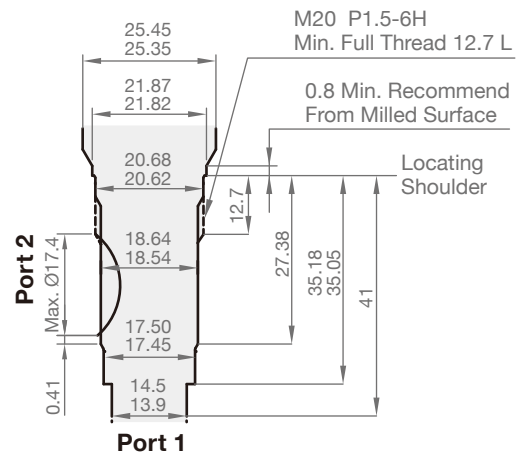

► T3A

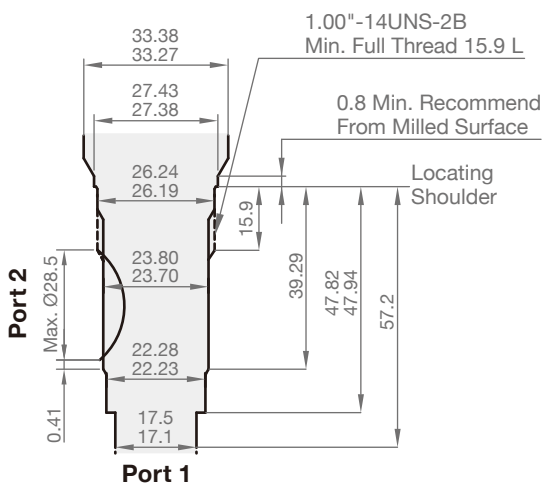

► T5A

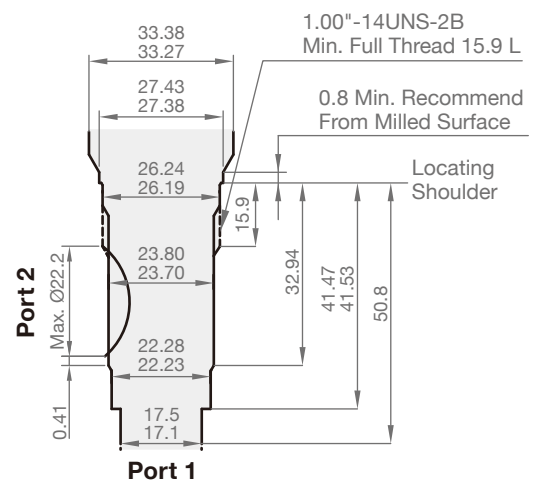

► T16A

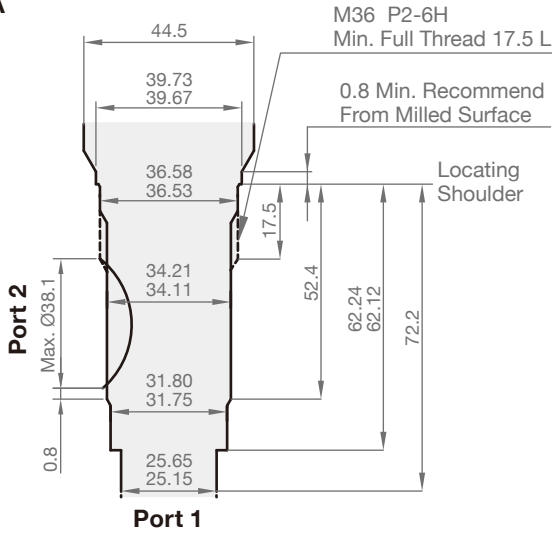

► T18A

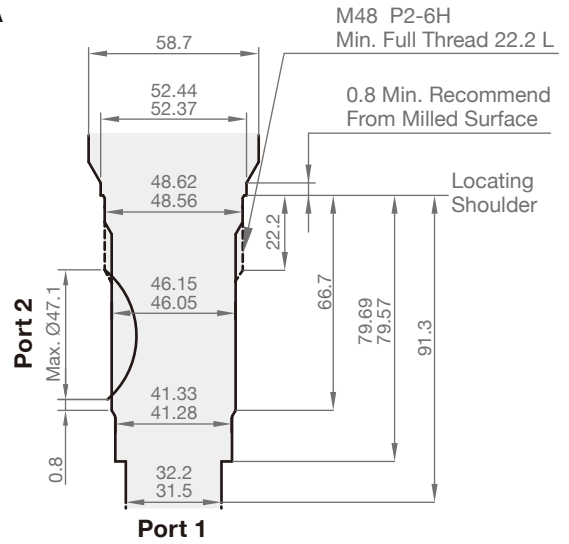

► T163A

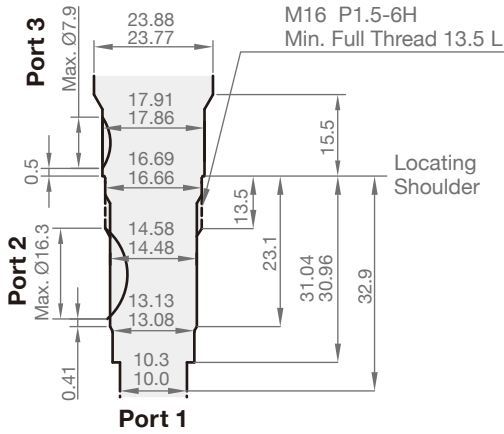

Size	Cavity
01	T163A
02	T11A
03	T2A
06	T17A
08	T19A

► T11A

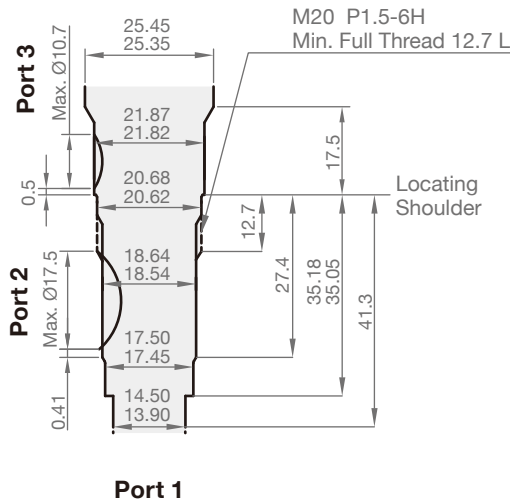

► T2A

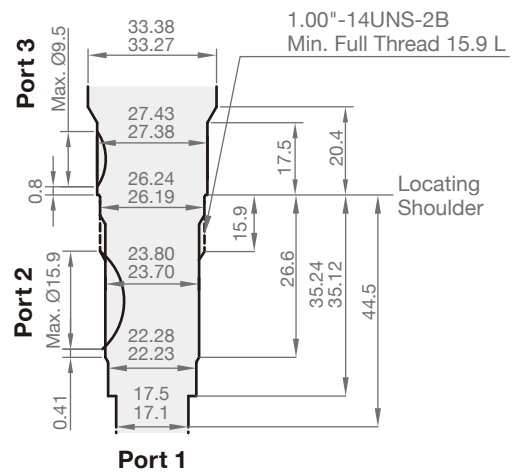

► T17A

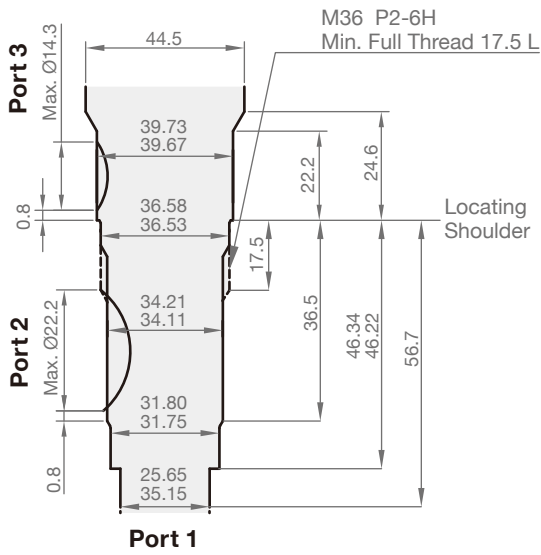

► T19A

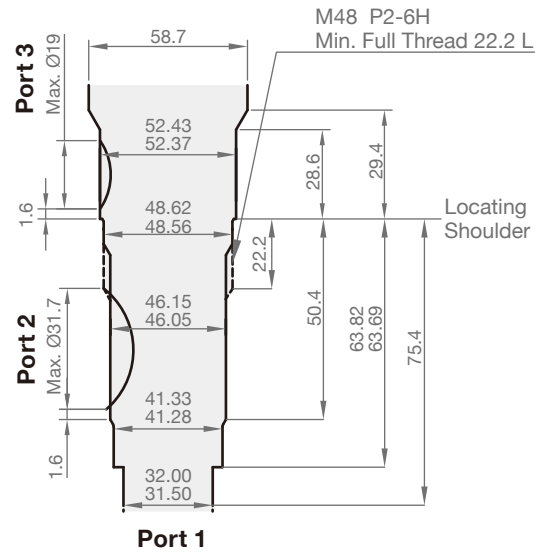

► T21A

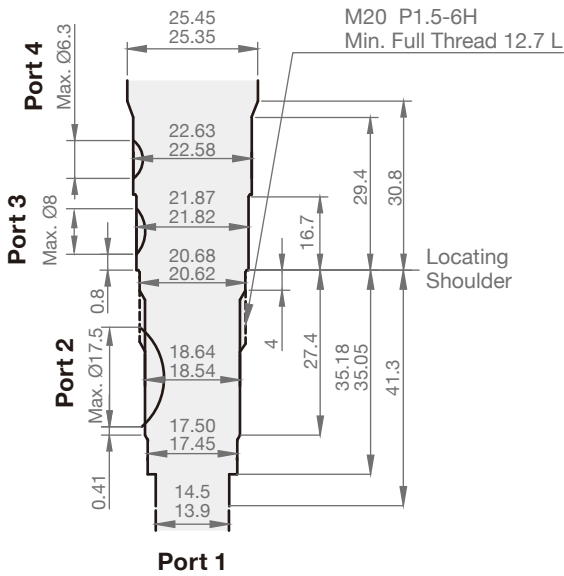

► T22A

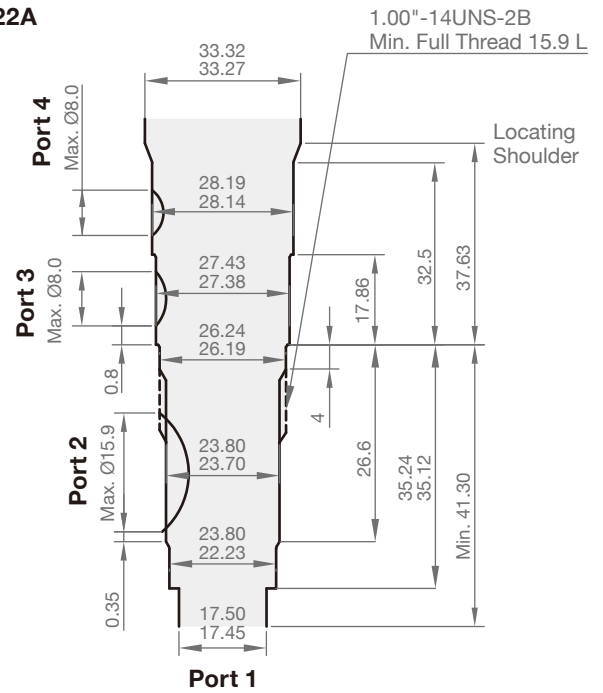

► T31A

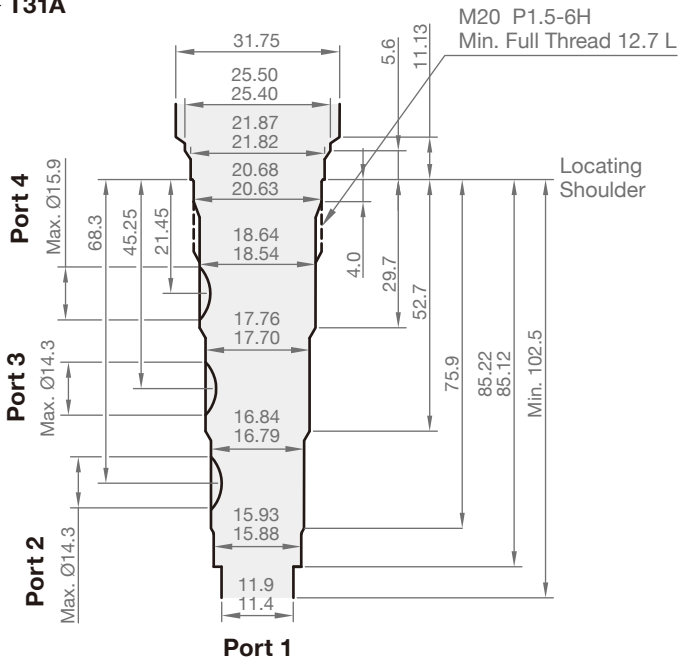

► T32A

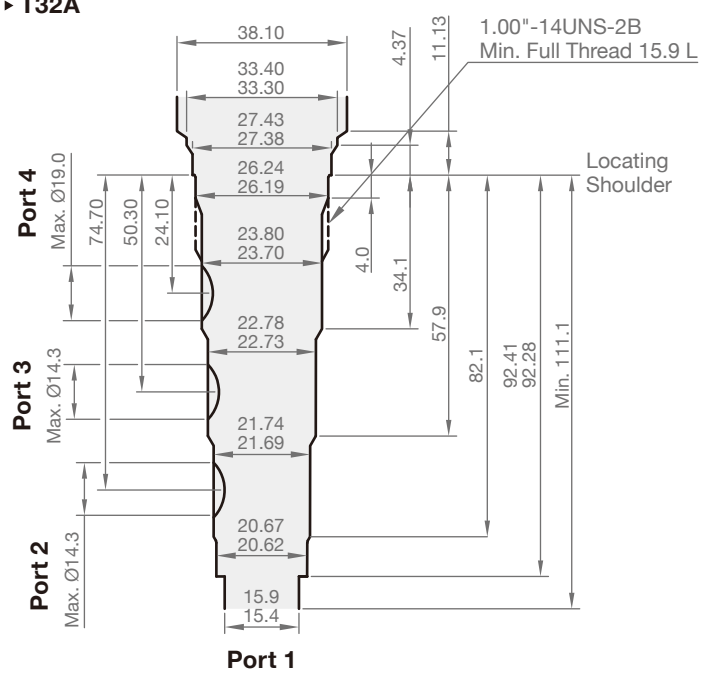

► T33A

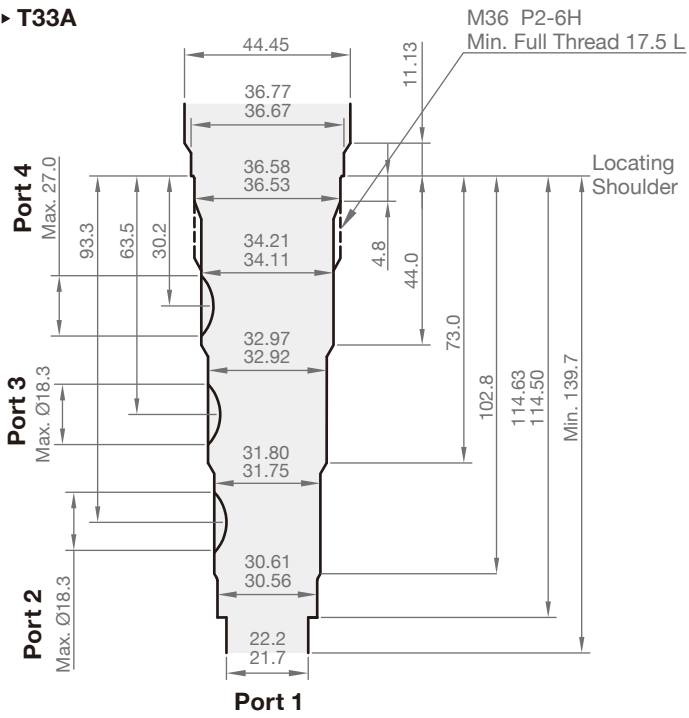

► T34A

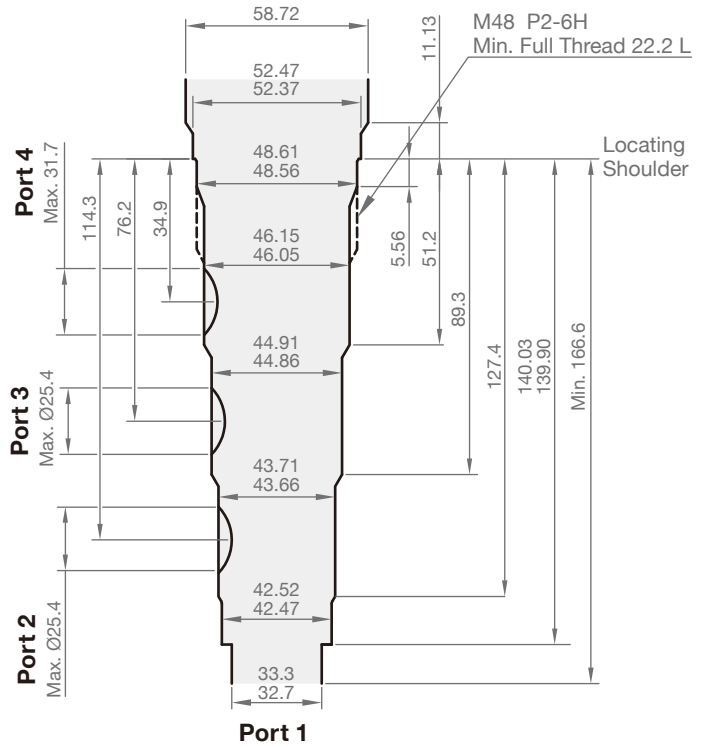

Cavities Tooling (SAE Cavity)

DIMENSION

(UNIT : mm)

► T82

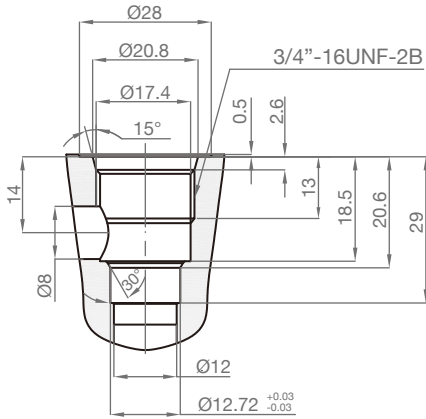

► T83

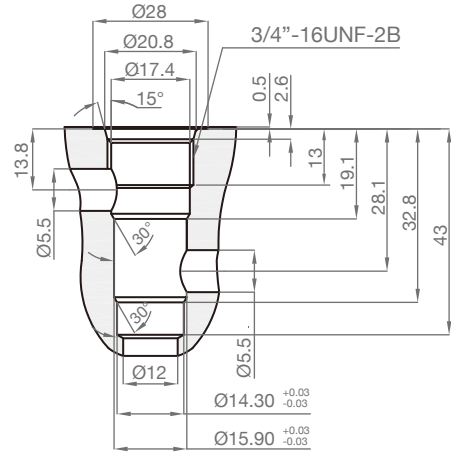

► T092

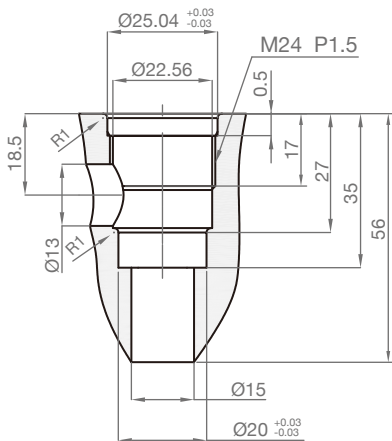

► T102

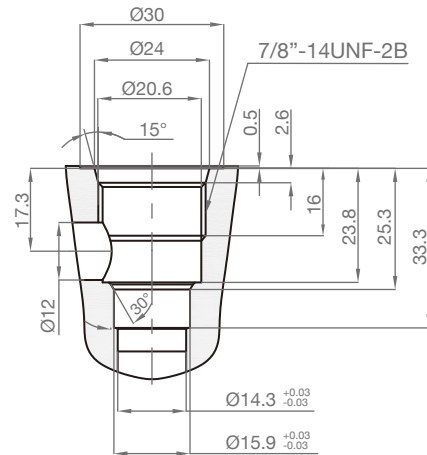

► T103

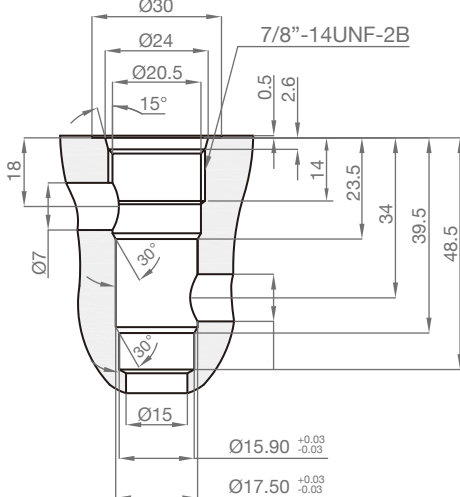

► T104

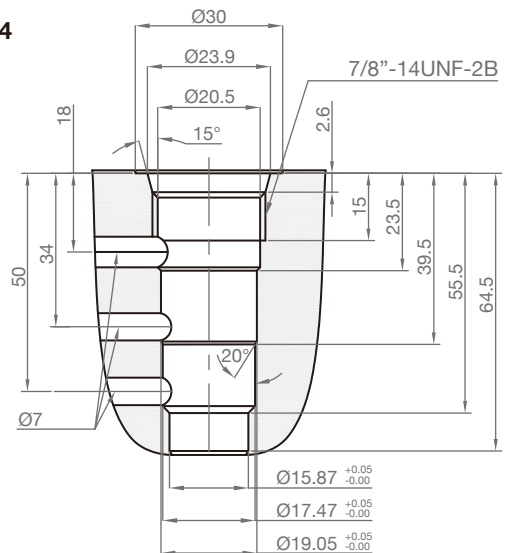

► T122

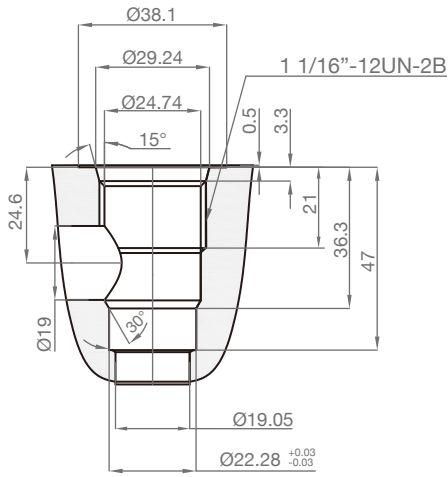

► T123

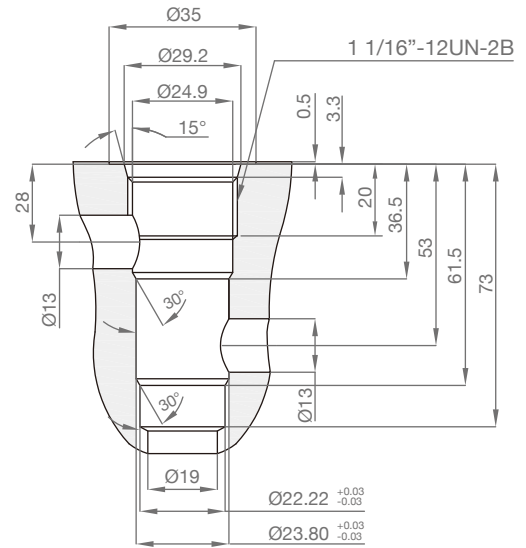

► T124

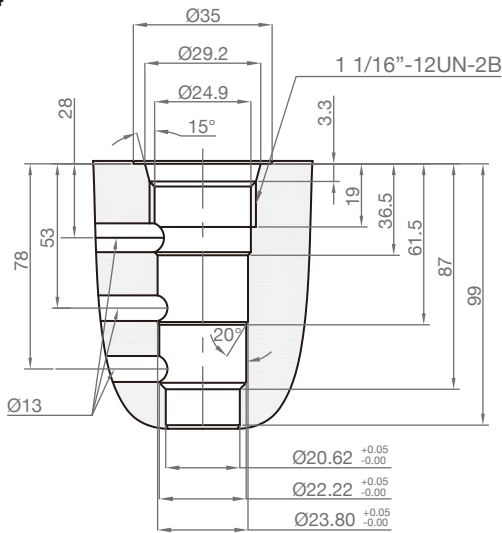

► T162

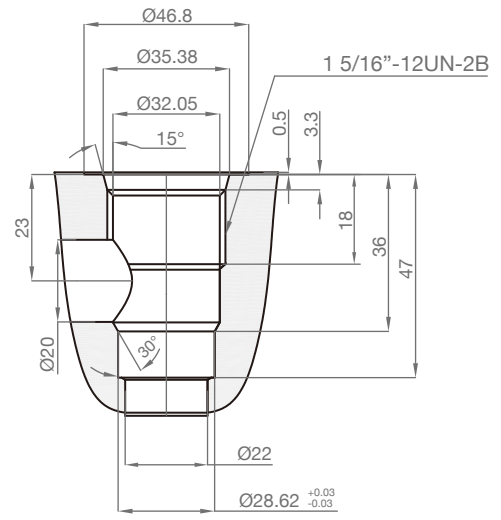

► T163

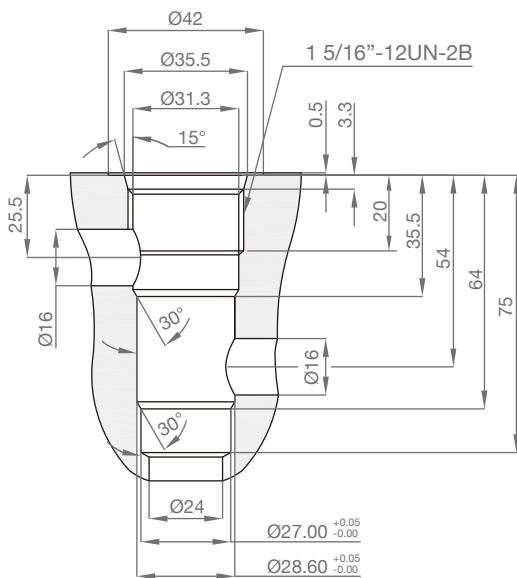

► T164

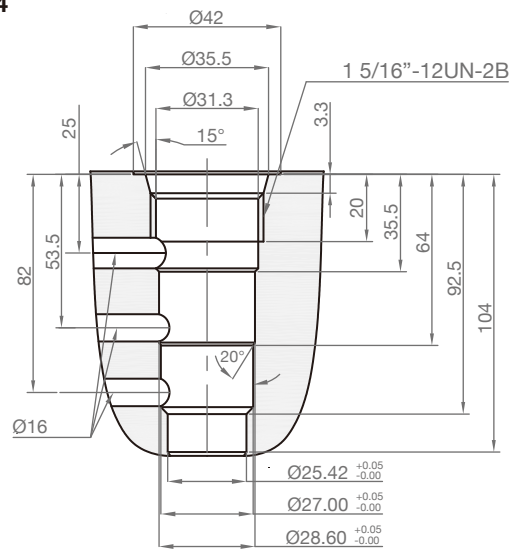

Steed Machinery Co., Ltd.

No. 28, Ruiguang St., South Dist.,
Taichung City 40249,
Taiwan
Tel : +886-4-2285-4867
Fax : +886-4-2285-2848
Email : info@steedmachinery.com.tw

more information
www.steedmachinery.com.tw

