

PP

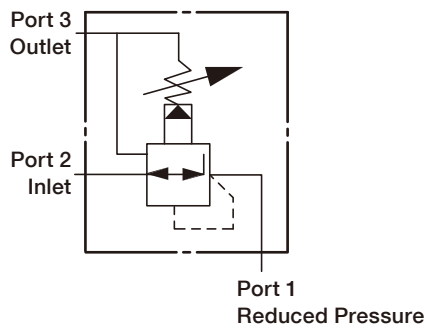

SYMBOLS



ORDER CODES

PP 2B - T11A - L A N

1 2 3 4 5 6

1	▶ Model Name	PP	
2	▶ Valve Size	2B, 3B, 6B, 8B	
3	▶ Cavity	T11A, T2A, T17A, T19A	
4	▶ Control Manner	L	standard screw adjustment
		K	hand knob with lock knob
5	▶ Adjustable Range	A	7 ~ 210 bar
		B	3.5 ~105 bar
		N	4~55 bar
		W	10~315 bar
6	▶ Material of Seal	N	buna-N
		V	viton

MODEL SPEC.

Model	Cavity	Capacity (l/min)	Max. Pressure (bar)	Installation Torque (Nm)	Operational Temperature	Weight (kg)
PP2B	T11A	40	350	40/50	-35 ~ 100°C (-31 ~ 212°F)	0.17
PP3B	T2A	80	350	60/70		0.30
PP6B	T17A	160	350	200/215		0.64
PP8B	T19A	320	350	465/500		1.43

PERFORMANCE CURVES

► Regulated Pressure

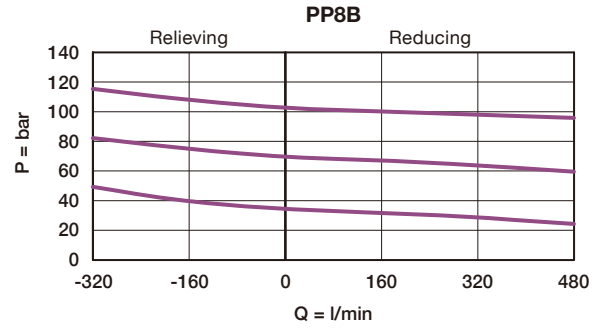
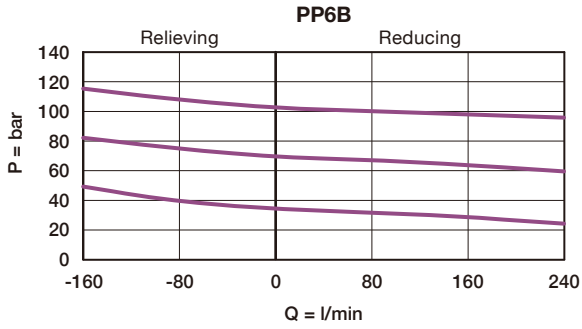
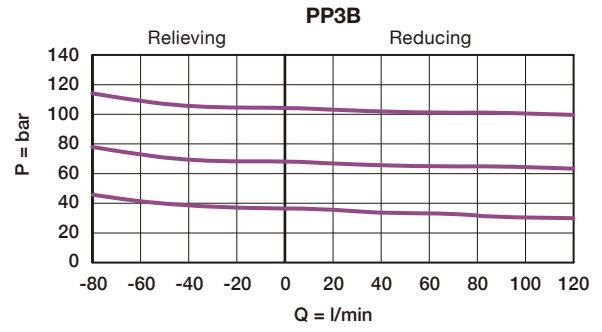
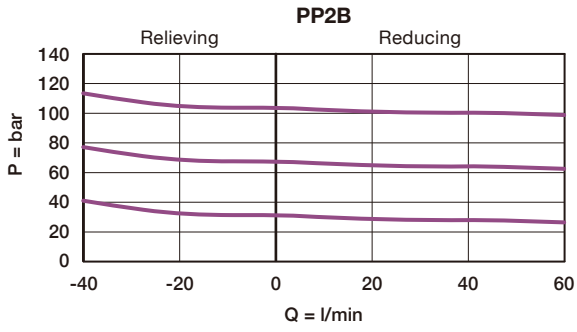

DIMENSION

(UNIT : mm)

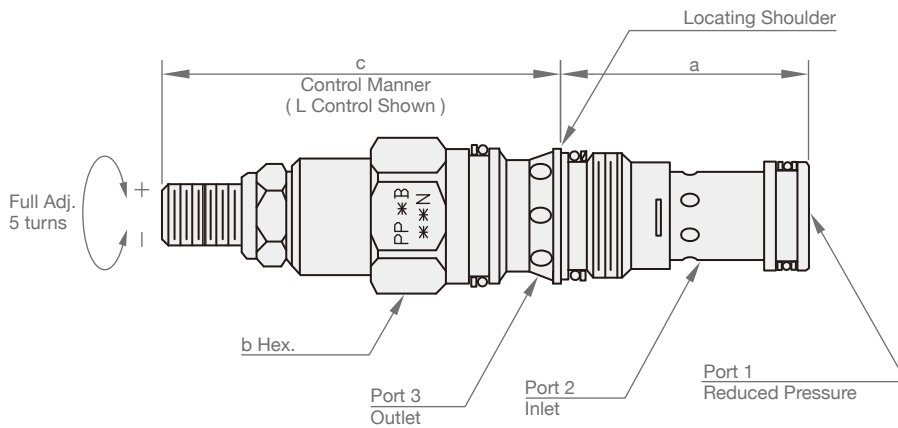

Model	a	b	c	
			L	K
PP2B	34.9	22.2	64	70
PP3B	34.9	28.6	72	78
PP6B	46.0	31.8	84	90
PP8B	63.5	41.3	100	107