

# RV

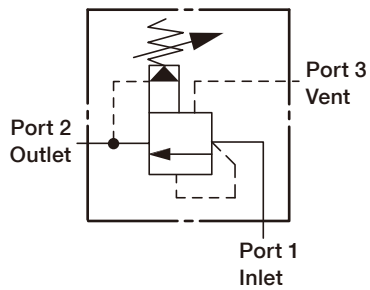

## SYMBOLS



## ORDER CODES

**RV 2A - T11A - L A N**

1      2                      3                      4      5      6

1	▶ Model Name	RV
2	▶ Valve Size	2A, 3A, 6A, 8A
3	▶ Cavity	T11A, T2A, T17A, T19A
4	▶ Control Manner	L    standard screw adjustment
		K    hand knob with lock knob
5	▶ Adjustable Range	A    7 ~ 210 bar
		B    3.5 ~105 bar
		C    10 ~ 400 bar
		E    2 ~ 25 bar
6	▶ Material of Seal	N    buna-N
		V    viton

## MODEL SPEC.

Model	Cavity	Capacity (l/min)	Max. Pressure (bar)	Installation Torque (Nm)	Operational Temperature	Weight (kg)
RV2A	T11A	60	350	40/50	-35 ~ 100°C (-31 ~ 212°F)	0.17
RV3A	T2A	120	350	60/70		0.30
RV6A	T17A	240	350	200/215		0.64
RV8A	T19A	480	350	465/500		1.43

## PERFORMANCE CURVES

### ► Vented Pressure

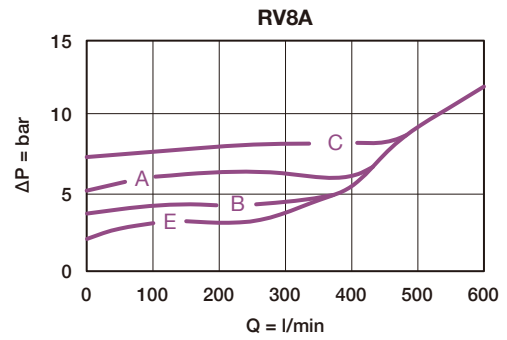
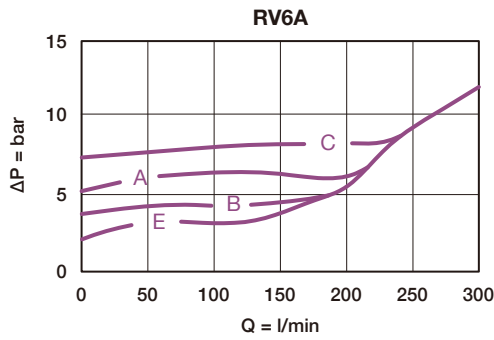
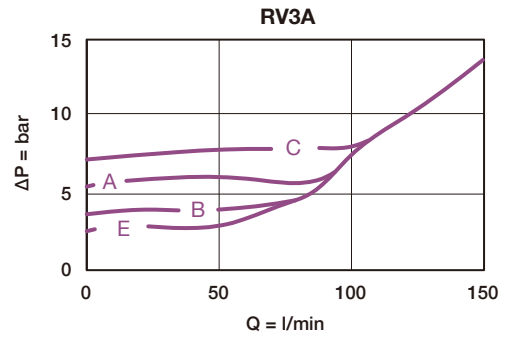
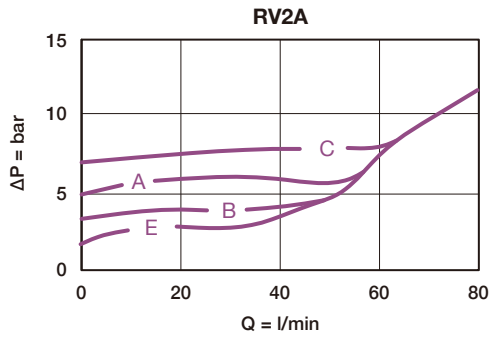

## DIMENSION

( UNIT : mm )

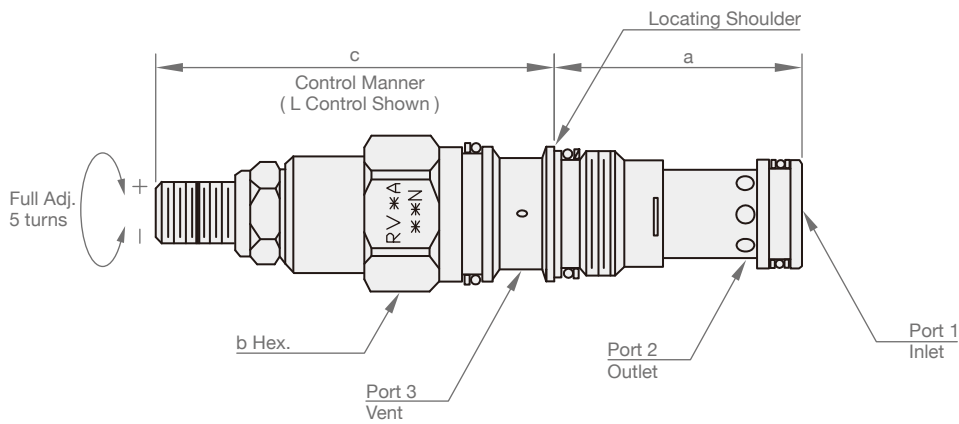

Model	a	b	c	
			L	K
RV2A	34.9	22.2	64	70
RV3A	34.9	28.6	72	78
RV6A	46.0	31.8	84	90
RV8A	63.5	41.3	100	107